

PRASAR BHARATI
INDIA'S PUBLIC SERVICE BROADCASTER
O/o THE ADDITIONAL DIRECTOR GENERAL (E) (WZ)
ALL INDIA RADIO& DOORDARSHAN
OLDCGOBUILDING, 3RD FLOOR, PRATISHTHA BHAVAN,
101, M. K. ROAD, MUMBAI-400 020.

ENGP (10KW FM TR, Dhule) 11 TR /

Date: 08.09.2019

Subject: - Supply and fitting of Glass / Nova pan Partition, Gypsum Board
False Ceiling and supply of power distribution board at AIR, Dhule.

This office is interested in carrying out following works as per details given below & attached specifications and invites your quotation.

Sr. No	Description of Work	Unit	Qty.	Place of Work
1.	Fabrication, supply & erection of glass partition in transmitter hall and UPS Room up to false ceiling made up of, 16 SWG Aluminum anodized square pipe of size 62mm x 38 mm & 12 mm strip beading with two hinged doors at both side corners and remaining part with sliding doors. Top vertical portion of the partition of suitable size (approx. 24 inch) will be made of Novapan sheet and remaining portion by 5 mm thick, plain, transparent, ISI grade Glass. The work includes all necessary hardware e.g. sliding hinges, channels, door locks, stoppers, heavy duty door closures etc. for the completeness of the work. The size of doors may vary as per site requirement. Glass specification: - 5 mm thick, plane transparent glass of ISI mark. Novapan specification: - 12 mm thickness. ISI grade. Approx. size of partition : TR Hall : - 20 ft. (L) X 10 ft. (H). UPS Room: - 10 ft.(L) X 10 ft. (Total size of partition- 300 sq.ft.)	1 Job	1	ALL INDIA RADIO, DHULE (M. S.)
2	Supply, Fabrication and Erection of False Ceiling in central AC plant room, with 600 mm x 600 mm x 10 mm thick, by using ISI grade-Jolly board/Amsterdam soft boards or other suitable and better alternative sheets such as ISI grade multipurpose plane cement sheets of 6 mm thickness on the existing wooden grid of size 600mm X 600mm. Size of false ceiling- 26 ft. X 10 ft. (260) sq. ft.	Job	1	
3	Design, fabrication and Supply of fully wired , wall mounted power distribution board (preferably on readily available multipurpose panel of L &T, INDO ASIAN, SIMENS, CROPTON Make) distribution panels with given specifications, line diagram and GA diagram in size 42 inch X 42 inch(maximum) by using MCCB's, MCB's, switches and complete suitable wirings, terminations, as per prevailing industry standards and Indian Electricity Rules etc. [MCCB's, MCB's, switches, meters, wires etc. used of Crompton, L&T, Schnider, Siemens, Havel's only will be accepted.]			
	All tools, materials, labours, scaffolding, etc. for carrying out the work is to be arranged by the tenderers. Safety precautions are to be followed strictly. Contractor will be responsible for any loss / damage to the equipment's during the work.			

The interested agencies/firms may visit the actual site on any working day during office hours with prior intimation and appointment from Assistant Engineer, AIR, Dhule (M.S.), **Phone No.(02562)271806/09422787695** before submitting the quotation.

* The successful tenderer will be decided on the basis of total cost involved.

2. The quotation should specifically **mention make, type of the items, delivery date,**

terms and condition of work / supply. The prices given should be firm and as under.

(a) The prices quoted shall remain fixed during the entire period of supply/contract and shall not be subject to variation on any account.

(b) The 'Unit' Price should be for the Unit as indicated in the tender enquiry.

(c) Prices quoted should be for F.O.R. Station of destination in India and inclusive of charges as packing customs, etc., wherever applicable.

(d) The quotation should specifically mention rates for supply & Taxes separately.

(e) The lowest tenderer will be decided for individual site on the basis of lowest coated price for each site.

3. In case of Quotation of F.O.R Station of dispatch basis, the purchaser will not pay separately transit insurance and the supplier will be responsible until the stores arrive in good condition at the destination. Tender/quotation in which transit insurance has been specified as an additional item of expenditure is liable to be ignored.

4. (A) Estimated cost is approx. Rs. 1, 99,000/= (Rs. One Lakh Ninety Nine Thousands only) including ALL applicable Taxes.

(B) **EMD:** Earnest Money amounting to **Rs. 4000/- (Rs. Four Thousand only)** in the form of Demand Draft on Nationalized Bank / Commercial Bank drawn In favor of **Prasar Bharati, CE(WZ), AIR & DD, Mumbai** should accompany the tender. Tenders without EMD shall be summarily rejected and their bid will not be opened at the time of tender opening and shall be rejected as non-responsive at the bid opening stage and returned to the bidder unopened. [EMD exemption is applicable for those who are registered with the Central Purchase Organization, National Small Industries Corporation (NSIC), MSME or the Concerned Ministry or Department [MIB / DG: AIR / DG:DD].

5.TAXES:

a.Payment of Entry Tax / Octroi Duty and Toll Tax (on ultimate products).

As the material, which is to be transported to the consignee, belongs to the Government of India/Prasar Bharati and therefore is exempted from Entry Tax/ Octroi Duty/Toll Tax. However, if the State Governments/Statutory Local Bodies are bound to levy such taxes, the taxes will be paid by supplier/ contractor. Supplier / Contractor should indicate such taxes on their prices quoted.

b. SGST / CGST/IGST leviable and intended to be claimed from the purchaser should be distinctly shown along with prices quoted. Where this is not done, no claim for SGST / CGST/IGST will be admitted at any later stage and on any ground whatsoever.

*** Please note that this Office will not issue any Form such as 'C', 'D' etc.**

6.Security Deposit: Security Deposit at the rate of 5 % of the contract amount, to be furnished by successful tenderer on award of contract. If not, it will be deducted from the first bill payment. The Security Deposit shall be furnished in the form of Demand Draft / Bank Guarantee drawn in favour of the **CE (WZ), AIR & DD, Mumbai-20**. The Security Deposit will be returned in full, on completion of successful Guarantee / Warranty Period.

7.WORK COMPLETION PERIOD: The entire work shall be completed within **Two Months** from the date of placement of order.

8.TERMS OF PAYMENT:100% payment will be released on satisfactory delivery of entire materials / stores and successful completion of work at site.

9. The quotation should be sent in a sealed cover addressed to the undersigned, **by name**, so as to reach on or **before 27/9/2019, at 1400Hrs.** on below mentioned address:

PRASAR BHARATI (BCI),
O/O ADDITIONAL DIRECTOR GENERAL (E) [WZ],
ALL INDIA RADIO AND DOORDARSHAN,
PRATISHTHA BHAVAN, 3RD FLOOR,
(AKASHWANI PROJECT SECTION)
101, M. K. ROAD, MUMBAI-400 020.

THE COVER SHOULD BE SUPERSCRIBED WITH THE FOLLOWING:

- a. **Supply/ Work for which quotations are enclosed.**
- b. **Reference to letter of enquiry.**

c. Due date AND time of opening quotation.

10. QUOTATIONS NOT PROPERLY SUPERSCRIBED AS ABOVE WILL NOT BE CONSIDERED.
11. The Quotations will be opened in this office at **1600** Hrs. on **27/09/2019** in the presence of tenderers or their agents such as they may choose to attend.
12. The quotations submitted shall remain open for acceptance for a period of 90 (Ninety) days from the date of opening of the Tender. If any tenderer/Suppliers **withdraws his Tender/Quotation before the said period or makes any modifications** in the Terms & Conditions on the Tender/Quotation which are not acceptable to the Department, then the Government shall, without prejudice to any other right or remedy, be at the liberty to forfeit 100% of the Earnest Money as aforesaid.
13. Both your **PAN - Permanent Income Tax Account Number, GST TIN - Tax Identification Number** should be definitely indicated in your quotation.
14. The contractor shall make his own arrangement for storage of all equipments and Materials bought to site from time to time and their safe custody at site till they are taken over by the indenter/his representative. The contractor shall make his own arrangement for providing accommodation for his workmen at site.
15. The contractor shall make his/her own arrangements for procuring necessary labour, skilled and unskilled. He should confirm to all local government laws and regulations covering labour and their employment.
16. The contractor and his employees shall comply with the regulation in force for controlled entry into premises where work is being carried out.
17. **Contractor liability for damage caused during installation work and imperfections noticed:** If the contractor or his/her workmen or servants shall break, deface, injure or destroy any part of the building in which they may be working or building road kerb, fence, enclosure, water pipe, cable, drain, electric or telephone posts or wires, trees, grass or grasslands or any Technical Equipment in the premises on which the work or any part of it as being executed, or if any defect, shrinkage or other faults appear in the work the contractor shall make good at his/her own expense, or in default, the indenter may get the same rectified and deduct the expense from any amount that may be than due or at any time thereafter may become due to the contractor.
18. The contractor shall take insurance for his men while working at **AIR, site**, against any injury, accidents death etc. Similarly, the equipment, instruments, tools etc, belonging to the constrictor shall be insured against damage, loss, theft etc.
19. While engaging labour for carrying out obligations under the contract, the contractor Shall satisfy the conditions laid down under contract labour (Regulation and Audition Act 1970 and (Central) Rules 1971 as amended from time to time and Observe all formalities required as per said Act/Rules. The contractor shall also observe the provision under minimum wages Act 1948 (Central) Rules 1950 amended from time to time while engaging labour.
20. The contractor shall indemnify and hold harmless the purchaser against all claims in respect of injury to any person howsoever arising out of the work in the course of such installation. The contractor shall discharge his entire obligation under the Indian Workmen Compensation Act in as for as it affects workmen in his Employment.
21. **RIGHT OF ACCEPTANCE:** The undersigned reserves the right to reject the lowest tender or all the tenders without assigning any reasons whatsoever. Further, the undersigned reserves himself the right to increase or decrease upto 50% of the quantity of goods and services specified in the schedule of the requirement without any change in the unit price of the order quantities or other term conditions at the time of award of contract. All Quotations/Tenders in which any of the prescribed conditions are not fulfilled or are incomplete in any respect are liable to be rejected. The competent authority on behalf of Prasar Bharati reserve himself the right of accepting the whole or any part of the Tender shall be bound to perform the same at the rate quoted.

- 22.** Canvassing whether directly or indirectly, in connection with Tender/quotation is strictly prohibited and the Tender/quotation submitted by the Contractors / suppliers who resort to canvassing will be liable to rejection.
- 23. LANGUAGE / UNITS:** All information supplied by the Tenderer & all markings, notes, designation on the drawings & associated write-ups shall be in "**English/Hindi language**" only. All dimensions, units on drawings, all references to weights, measures & quantities shall be in MKS.
- 24.** In case this is second enquiry, your Quotation in response to the first enquiry should be presumed to be valid up to 180 days from the last date mentioned in para. 11 above unless we hear from you.
- 25. Eligibility Criteria:** The tenderer should give documentary proof for having successfully completed / supplied similar type of works / material /equipment/stores.
- 26. FAILURE AND TERMINATION CLAUSE:-** Time and date of delivery shall be essence of the contract. If the Contractor / Supplier fails to deliver the stores / execute SITC / SETC, or any instalment thereof within the period fixed for such delivery in the schedule or at any time repudiates the contract before the expiry of such periods, the purchaser may without prejudice to any other right or remedy, available to him to recover demurrages for breach of the contract:-
- (a)** Recover from the Supplier/Contractor as agreed, liquidated demurrages including Administrative expenses and not by way of penalty, a sum equivalent to 0.5 % per week up to maximum limit of 10% of the contract value for such delay or part thereof (this is an agreed, genuine pre-estimate of demurrages duly agreed by the parties) which the supplier/contractor has failed to deliver thereof is accepted after expiry of the aforesaid period, provided that the total demurrages so claimed shall not exceed 10% of the contract price of the stores / SITC / SETC. After full period of extension, termination of the contract will be considered by the Organization.
 - (b)** Purchase or authorize the purchase elsewhere on the account and at the risk of the contractor/supplier, of the stores not so delivered / SITC / SETC not carried out or other of a similar description (where stores exactly complying with the particulars are not in the opinion of the purchaser, which shall be final, readily procurable) by serving prior notice to the contractor/supplier without cancelling the contract in respect of the instalment not yet due for delivery or,
 - (c)** Cancel the contract or a portion thereof by serving prior notice to the Contractor/Supplier and if so desired purchase or authorize the purchase of the stores not so delivered / SITC / SETC not carried out, or others of a similar description (where stores not delivered / SITC / SETC not carried out, exactly complying with particulars are not in the opinion of the purchaser, which shall be final readily procurable) at the risk and cost of the Contractor/Supplier. If the Contractor/Supplier had defaulted in the performance of the original contract, the purchaser shall have the right to ignore his tender for risk purchase even though the lowest, where the contract is terminated at the risk and cost of the firm under the provisions of this clause, it shall be in the discretion of the purchaser to exercise his discretion to collect or not, the Security deposit from the firm on whom the contract is placed, at the risk and expense of the defaulted firm.
 - (d)** Where action is taken under sub-clause (b) or sub-clause (c) above, the contractor shall be liable for any loss which the purchaser may sustain on that account, provided the purchase or if there is an agreement, to purchase, such agreement is made in case of failure to deliver the Stores/Services, within 6 months from the date of such failure and in case of repudiation of contract the Contractor/Supplier shall not be entitled to any gain on such the entire discretion of the purchaser to serve a notice of such purchase on the Contractor/Supplier.
 - (e)** It may further be noted that clause (a) above provides for recovery of liquidated demurrages on the cost of contract price of delayed supplies (whole unit) at the rate of 0.5% per week up to maximum limit of 10% of the contract value for such delay or part thereof. Liquidated demurrages for delay in supplies thus accrued will be recovered by the paying authority on instruction as specified in the supply order, from the bill for payment of the cost of materials / works submitted by the supplier / contractor in accordance with terms of supply order on instruction from Purchaser regarding liquidated demurrages amount.

- (f) Notwithstanding anything stated above, equipment and materials will be deemed to have been delivered / SITC / SETC will be deemed to have been carried out only when all its components, parts are also delivered. If certain components of stores are not delivered in time / SITC / SETC not carried out in time, the stores / SITC / SETC will be considered as delayed until such time all the missing parts are also delivered.

27. If a dispute arises out of or in connection with the contract, or in respect of any defined legal relationship associated therewith or derived there from, the parties agree to submit that dispute to arbitration under ICADR Arbitration Rules; 1996. The Authority to appoint the arbitrator(s) shall be the International Centre for Alternative dispute resolution. The International Centre for Alternative Dispute Resolution will provide administrative services in accordance with the ICADR Arbitration Rules, 1996.

- a) The number of arbitrator(s) shall be one who has legal as well as Technical Background.
b) The place of arbitration proceedings shall be **Mumbai only**.

28. GENERAL: - All the pages of the tender document should be duly signed, stamped and serially numbered on submission, failing which the tender may not be considered as qualified tender.

Web Site: <https://www.prasarbharati.gov.in> , <https://www.allindiaradio.gov.in>

(P.M.KHAPKE)
Assistant Engineer
For ADG (E-WZ)
Tele: 022 -22053528

ANNEXURE-I

GENERAL TERMS AND CONDITIONS FOR SUPPLY ORDER

- 1) NAME OF PURCHASE : Prasar Bharati
2) PAYING AUTHORITY : The ADG (E-WZ), AIR & DD, Mumbai.
3) PAYMENT TERMS : 100% payment will be released on satisfactory delivery of entire Materials / stores and successful completion of work on site.

4) BILLS: All the supplies and works shall be in conformity with the order and all the part bills shall be prepared in quadruplicate in the same format as that of the Supply Order. All those part bills shall be submitted to the consignee for necessary certificates and onward transmission to the paying authority.

5) DESPATCH INSTRUCTIONS:

The packing and marking of goods shall be as laid down in clause-12 of general conditions of contract DGS D69 (revised).

6) The contractor shall arrange to dispatch the goods duly insured direct to the consignee under prior intimation for delivery at site by whichever mode of transport he may choose, to ensure safe delivery of goods at site. Unloading shall be done at site at the contractor's expense. The consignee will provide only storage space. The contractor will provide his own security like locking etc., and store the materials at his own risk.

7) INSPECTION:

The material/works will be inspected at site. All necessary tools/equipment's will be arranged by the manufacturer / tenderer. If required any other tests required to be necessary will be required to be carried out for which arrangement is to be made by the manufacturer / tenderer. In case of disputes third party inspection will be carried out as per BIS standard for which charges will be borne by the firm / tenderer. If any damages are found, material will be rejected.

8) INSURANCE: The contractor shall arrange for the insurance covering the risk during transit, storage. All the charges for such insurance shall be borne by the contractor.

9) ADDITIONAL QUANTITIES:

The purchaser reserves the right to place order for additional quantity up to 50% of the ordered quantity at the same rates and terms and condition during the currency of the contract.

10) PENALTY FOR DELAY

If the contractor is unable to complete the supply, installation, testing and commissioning within the stipulated time limit the purchaser may at his option allow such additional time as may be considered justified with/without penalty and without altering terms and conditions of the order. In the event of failure of the contractor to complete the supply, installation testing and commissioning within the stipulated time or the extended time, the purchaser has the right to impose penalty of **0.5%** per week or part thereof the contract price. The Contractor's liability for delay, however, shall not exceed 10% of the total contract price.

11) GUARANTEE/ WARRANTY:

The contractor shall accept clause-18 of the Form no. DGS & D-71 with exception that his obligation shall be limited for a period of 12 months from the date of taking over completion of the successful performance excluding down time during which the equipment was not working satisfactorily due to defective parts, faulty material/ design/workmanship or faulty erection. During the guarantee period the contractor shall repair or replace free of charge any parts that will become defective due to faulty material design, workmanship.

12) CONDITIONS OF CONTRACT:

A. DGS & D-68 (Revised) and DGS & D-71 as amended up to date. However, such of these conditions stipulated on this tender shall supersede corresponding conditions in DGS & D-71.

B. The contractor shall submit the duplicate copy of supply order duly signed and stamped along with acceptance letter and Security Deposit within 2 weeks. No supplies will be made and no work shall start unless the acceptance is signed by the contractor.

13) FORCE MAJEURE: If any time during the continuance of the contract the performance in whole or in part by the contractor shall be prevented or delayed by reason of any war, hostility acts of the public enemy. Civil commotion, sabotage, fires, floods, explosions, epidemics, Quarantine restrictions, strikes, lock-outs or acts of God (therein after restrictions refer to as events and provided notice of happenings of any such eventuality is given by the contractor within 21 days from the date of occurrence thereof, the purchaser shall by reason of such event, neither be entitled to cancel this order nor shall have any claim for damages against the contractor in respect of such non-performance or delay in performance and delivery shall be resumed as soon as practicable after such events have come to an end or ceased to exist.

Provided further that if the performance in whole or part or any obligation under this order is prevented or delayed by reasons of any such event for a period exceeding 180 days, the purchaser and the contractor shall meet to find a neutral agreement to any effect resulting the reform or the purchaser may at his option cancel order provided also if the order is cancelled under this clause, the purchaser shall be at liberty to take over from the contractor at order prices all unused, un-damaged and acceptable material bought out components and stores in course of manufacture in the possession of the supplier at the time of such cancellation or such portion thereof as the purchaser may deem fit accepting such material, bought out components and stores as the supplier may with the concurrence of the purchaser elect to retain.

14) CANCELLATION:

The purchaser reserves the right to cancel the order in the event of non-performance / delay in execution of the work or unsatisfactory performance by the contractor and recover payment already made if any, along with losses/ damages incurred.

(P.M.KHAPKE)
Assistant Engineer
For, ADG (E-WZ)
Tele: 022 -22053528

Schedule of Requirement/bill

Name of Work: Supply and fitting of Glass / Nova pan Partition, Gypsum Board False Ceiling and supply of power distribution board at AIR, Dhule.

Sr.	Description of Work	Unit	Qty	Amount
1.	<p>Fabrication, supply & erection of glass partition in transmitter hall and UPS Room up to false ceiling made up of, 16 SWG Aluminum anodized square pipe of size 62mm x 38 mm & 12 mm strip beading with two hinged doors at both side corners and remaining part with sliding doors. Top vertical portion of the partition of suitable size (approx. 24 inch) will be made of Novapan sheet and remaining portion by 5 mm thick plain ISI grade Glass. The work includes all necessary hardware e.g. sliding hinges, channels, door hinges, stoppers, heavy duty door closures etc. for the completeness of the work. The size of doors may vary as per site requirement.</p> <p>Glass specification: - 5 mm thick, plane transparent glass of ISI mark.</p> <p>Novapan specification: - 12 mm thickness. ISI grade.</p> <p>Approx. size of partition: TR Hall : - 20 ft. (L) X 10 ft. (H). UPS Room : - 10 ft.(L) X 10 ft. (Total size of partition- 300 sq. Ft.)</p>	1 Job	1 Lumb sum	
2	<p>Supply, Fabrication and Erection of False Ceiling in central AC plant room, with 600 mm x 600 mm x 10 mm thick, by using ISI grade-Jolly board/Amsterdam soft boards or other suitable and better alternative sheets such as ISI grade multipurpose plane cement sheets of 6 mm thickness on the existing wooden grid of size 600mm X 600mm.</p> <p>Size of false ceiling- 26 ft. X 10 ft. (260) sq. ft.</p>	1 Job	1 Lumb sum	
3	<p>Design, fabrication and Supply of fully wired , wall mounted power distribution board (preferably on readily available multipurpose panel of L &T, INDO ASIAN, SIMENS, CROPTON Make) distribution panels with given specifications, line diagram and GA diagram in size 42 inch X 42 inch(maximum) by using MCCB's, MCB's, switches and complete suitable wirings, terminations, as per prevailing industry standards and Indian Electricity Rules etc.</p> <p>[MCCB's, MCB's, switches, meters, wires etc. used of Crompton, L&T, Schnider, Siemens, Havel's only will be accepted.]</p>	1 Job	1 Lump sum	
	TOTAL Amount			
	APPLICABLE GST	SGST/UGST @	%	
		CGST @	%	
		IGST @	%	
	Any other Charges			
	GRAND TOTAL			
Rupees (In words):				

SIGNATURE AND SEAL Of THE
CONTRACTOR/FIRM

GA DIAGRAM

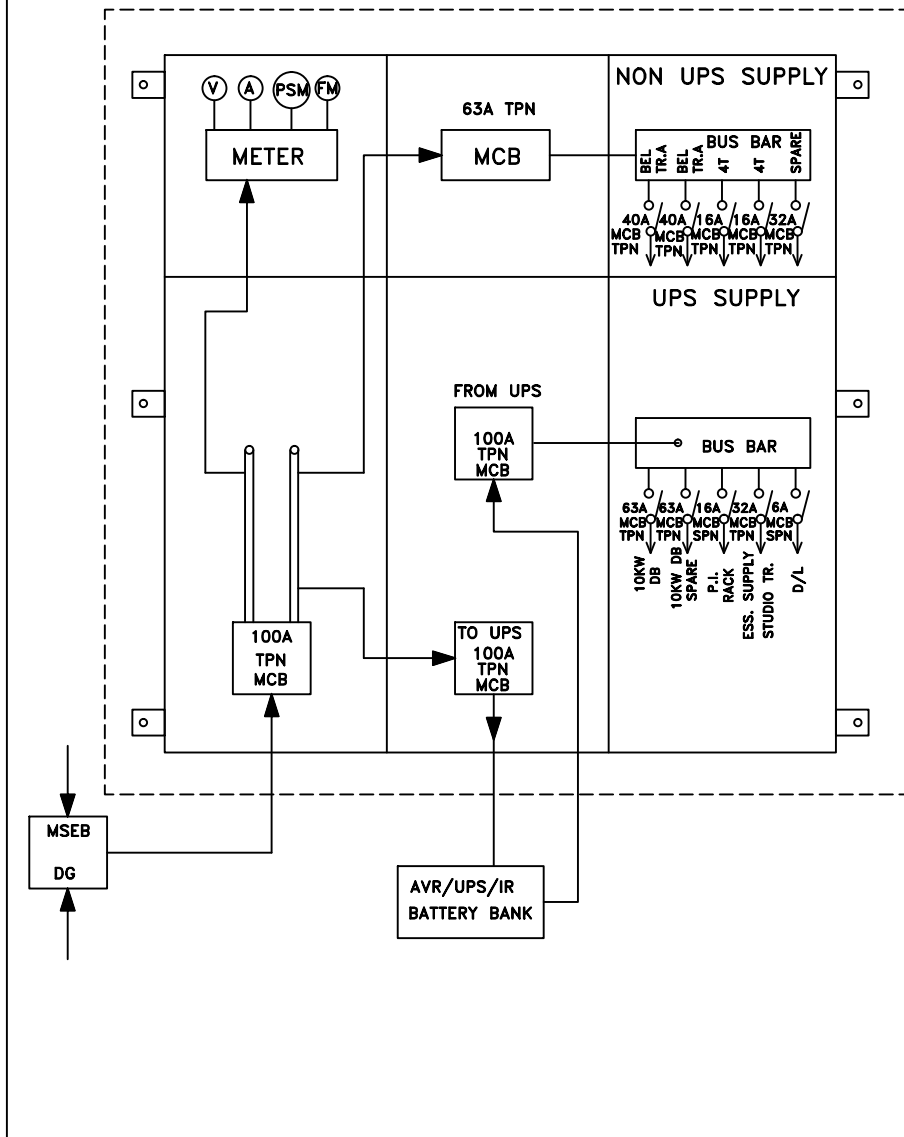

LINE / SCHEMATIC DIAGRAM, SDB AIR DHULE

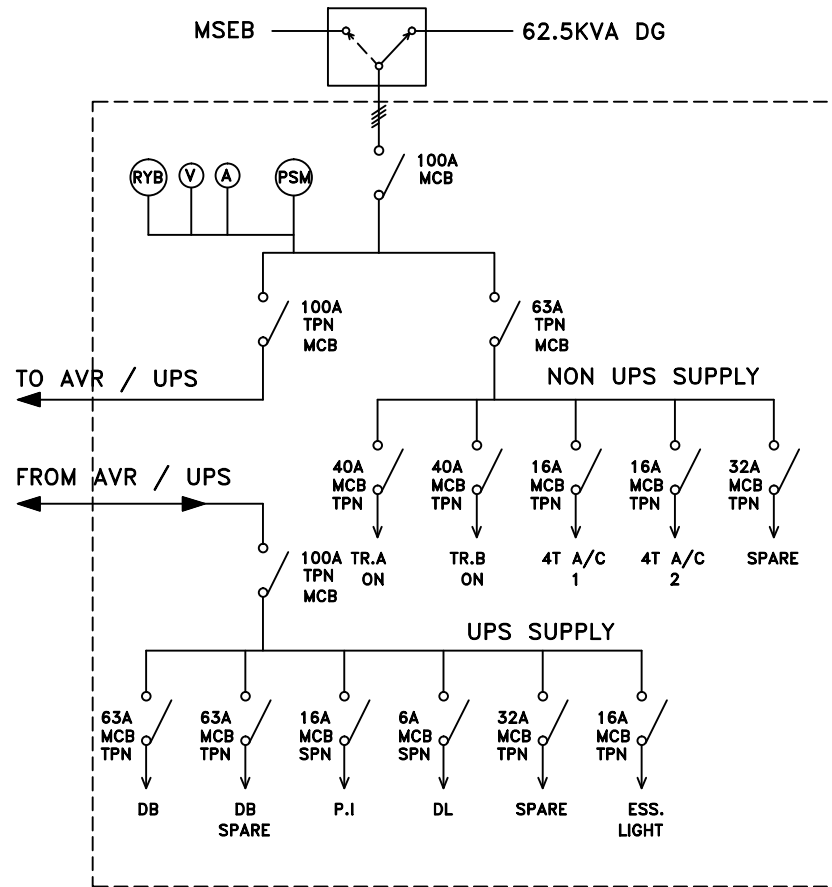

PRASARBHARTI (BROADCASTING CORPORATION OF INDIA) O/O ADDITIONAL DIRECTOR GENERAL (ENGG.) WZ AIR & DOORDARSHAN, MUMBAI-20.	
LINE / SCHEMATIC DIAGRAM SDB, AIR DHULE	
SCALE:-	DRAWING NO.-
DRN. A.KORE. 05/9/19	CEW-1623/2019
CHD. P.M.K. 05/9/19	
APPD.	