

Through PB website

**PRASAR BHARTI
(India's Public Service Broadcaster)
Directorate general of Doordarshan
Doordarshan Bhawan, Copernicus Marg
New Delhi -110001.**

File No. 19(2)2023-24EI(P)TVDraftspecifications

Dated : 13/08/2024

Subject: Technical Specification along with Suggestive Bill of Material (BOM) for SITC of Upgradation & Replacement of Earth Station at DDK Itanagar, Agartala, Kohima, Imphal, Gangtok and Port Blair.

The Technical specification of the upcoming tender is enclosed herewith to offer comments/Industry Feedback and budgetary quote if any by prospective bidders/ Firms on or before due date at e-mail ddpurchase401@yahoo.co.in or on following Address:

Assistant Engineer
Room No. 403,
Directorate General: Doordarshan,
Doordarshan Bhawan, Copernicus Marg,
New Delhi -110001 (India)
Telephone: 011- 2311 4401

Specification For: SITC of Upgradation & Replacement of Earth Station at DDK Itanagar, Agartala, Kohima, Imphal, Gangtok and Port Blair.

Specification no: SATD/Upgradation_6ES/August_24 dated 06.08/2024

Due Date to offer Comments: **28.08.2024 at 17.00 hrs.**

Encl.: As above (63 Pages)

Signed by Narendra Kumar
Choursiya
Date: 13-08-2024 17:51:22
Reason: Approved
Assistant Engineer
For DG:DD

Prasar Bharati
Directorate General: Doordarshan
Doordarshan Bhawan: Copernicus Marg
New Delhi-110001

**Technical Specifications for
SITC of Upgradation & Replacement
of Earth Station at
DDK Itanagar, Agartala, Kohima,
Imphal, Gangtok and Port Blair**

Specification No.: SATD/Upgradation_6ES/August_24

Date: 06.08.2024

[Handwritten Signature]
06.08.2024

[Handwritten Signature]
6/8

[Handwritten Signature]

**Technical Specification for Upgradation & Replacement of Earth Station at DDK
Itanagar, Agartala, Kohima, Imphal, Gangtok and Port Blair**

Index

S. No.	Description	Page no.
1	Introduction	3
2	Scope	4
3	Work Experience	6
3.1	• Selection of the vendor	6
3.2	• OEM of Professional IRD and Encoder	6
3.3	• OEM of Satellite Modulator	7
3.4	• OEM of 2x20KVA UPS System	7
4	Turnkey implementation and commissioning	8
5	Technical Specifications of Major Equipment	11
5.1	• Embedder, De-embedder, Distribution Amplifier and OFC Link	11
5.2	• Equipment of Compression and IF System	15
5.3	• Monitoring & Measuring System	25
5.4	• Power Supply System (UPS, Battery, Isolation Transformer and AVR)	34
6	Physical, Environmental & Mechanical Specifications	44
7	Complement of Equipment for the Earth Station	45
8	General	46
8.1	Compliance and OEM Authorization	46
8.2	Documentation	47
8.3	Guarantee	48
8.4	Inspection and Commissioning	48
8.5	Delivery Period	49
8.6	Pre-bid Conference	49
8.7	Check List and Enclosures	49
Annexure-II	CERTIFICATE FOR AUTHORIZATION	51
Annexure-III	CERTIFICATE FOR GUARANTEE	52
Annexure-IV	CERTIFICATE FOR AFTER SALES SERVICE SUPPORT	53
Annexure-V	DECLARATION BY THE BIDDER	54
Annexure-VI	CERTIFICATE OF WORK EXPERIENCE	56
Annexure-VII	Tool Kit	57
Annexure-VIII	Diagram-1 to Diagram-4	58-61
Annexure-I	Bill of Material (BOM)	62-63

Handwritten signature and date: 27/05/2024

Handwritten initials: JAL

1. Introduction

This project envisages Supply, Installation, Testing & Commissioning (SITC) for Upgradation & Replacement of Earth Station at DDK Itanagar, Agartala, Kohima, Imphal, Gangtok and Port Blair comprising of Compression System, IF System, Monitoring System and Power Supply system under plan scheme Upgradation & Replacement of 2x(1+1) Earth Station for SD and HD TV Channels.

Compression System, IF System, Monitoring System and Power Supply system of these earth stations is proposed to be provided for uplinking of SDTV & HDTV channels (Anyone standard on any given point of time) with MPEG-2/MPEG-4 compression and Uplink in DVB-S/DVB-S2 standard.

Configuration of major equipment for the proposed Earth Station Chain

S. No.	Configuration of Equipment	Uplink Standard	Remarks
1.	2x(1+1) Stand-alone Encoder for SDTV in MPEG-2 & MPEG-4 and HDTV in MPEG-4 compression in 4:2:0, 4:2:2 format for both SDTV and HDTV (Anyone standard on any given point of time)	SDTV & HDTV	SITC of 2x(1+1) encoders.
2.	Satellite Modulators 2x(1+1)	DVB-S & S2 Systems	SITC of 2x(1+1) Satellite Modulators
3.	Monitoring System consisting of: <ul style="list-style-type: none"> • L band IRD • A/V Monitors 	SDTV & HDTV	SITC of Monitoring System
4.	Power Supply System consisting of: <ul style="list-style-type: none"> • 2x20KVA UPS • 30 KVA AVR • 30 KVA Isolation Transformer 	-	SITC of Power Supply System

Table 1

2. Scope of Work

The scope of the work at Digital Earth Station at DDK Itanagar, Agartala, Kohima, Imphal, Gangtok and Port Blair on turnkey basis shall include the following but not limited to (Please refer DRG: 1 to 4):

- 2.1 Supply, Installation, Testing & Commissioning of the Digital Earth Station for two carrier up-link configuration consisting of HD/SD-SDI router and compression chain having MPEG-2 and H.264/MPEG-4 AVC Encoders in 2x(1+1) mode.
- 2.2 Supply, Installation, Testing & Commissioning of DVB-S, S2 (any one at a time) compliant Digital Modulators in 2x(1+1) configuration with IF redundancy switch (inbuilt or external).
- 2.3 Provision for confidence monitoring points at the following locations for the Earth Stations mentioned below with 17" video monitor and 8 channel audio bar graph.
 - (i) **Monitoring of SDI Input Source:** Monitoring of SDI (Audio embedded) inputs through SDI/ASI router with 17" Video monitor, 8 channel Audio (Bar Graph) Monitor and dual 9" Monitors rack mount.
 - (ii) **Monitoring of ASI output of Encoders:** Monitoring of ASI output of encoders through SDI/ASI routers using IRD (with ASI input), 17" TFT monitor with speaker, 8 channel Audio (Bar Graph) Monitor.
 - (iii) **IF Monitoring:** Monitoring of 70 MHz output of Modulators through existing IF Patch panel, which is to be converted to L-Band using existing Up-converter (70MHz to L-band), IRD (L band input), SDI/ASI router, 17" TFT monitor and 8 channels Audio (Bar Graph) Monitor.
 - (iv) **RF Uplink Monitoring:** Monitoring of output of existing Up-converters and existing HPA through existing RF Patch Panel, existing Test Loop Translator (TLT- C-band U/L to L- band converter), IRD (L-band input), SDI/ASI router and 17" TFT monitor and 8 channels Audio (Bar Graph) Monitor.
 - (v) **RF Downlink Monitoring:** Monitoring of downlink signal coming from existing LNA (both V & H) and existing down converters through existing RF Patch Panel and IRD (with L band input) via SDI/ASI router with 17" Video monitor, 8 channels Audio (Bar Graph) Monitor and dual 9" Monitors rack mount.
- 2.4 The system shall be designed to meet the International standards for digital Satellite Broadcasting having MPEG-2 & H.264/MPEG-4 AVC compression and DVB-S, S2 modulation (one at a time).
- 2.5 The bidder shall provide fully wired 19" standard equipment racks for mounting all the offered indoor equipment along with interconnecting power/signal/audio/ video cables and connectors etc.
- 2.6 The bidder shall install, interconnect, test and commission the offered baseband, Compression, IF equipment, Monitoring System and make the Earth Station operational in 2x(1+1) configuration.

[Handwritten signature]

[Handwritten signature]

[Handwritten signature]

- 2.7 The bidder has to integrate and configure the new equipment chains and commission the system as per the scope of the project and configuration mentioned in table-1 at clause 1.
- 2.8 Assorted items required for the project like Rack Frames, MDUs, Audio, Video Power supply and control Cables with associated connectors and 1:4 IF splitter etc. are also to be provided.
- 2.9 The bidder should provide the required number of (Min. 4 Nos.) earth pits for the Earth Station at each site.
- 2.10 The bidder shall provide Power supply system which includes three phase 2x20 KVA parallel redundant, solid state Uninterrupted Power Supply (UPS) along with battery bank, battery bank change over switch, switches and interconnecting cables for (1+1) parallel redundant load sharing mode and Standalone operation of UPS, each UPS operating with a minimum 15 minutes battery backup at full rated capacity, 30 KVA Isolation Transformer, 30 KVA Automatic Voltage Regulator (AVR), Power Distribution Panel (PDP) and Mains Distribution Boards etc. The suggestive single line diagrams of UPS are enclosed in Drawing No 2.
- 2.11 The Bidder should install remote Monitoring Panel for monitoring of UPS system in the Control room.
- 2.12 The UPS system has to operate in conjunction with the existing Building Electrical System, existing Diesel Generator (62.5/125 KVA) and Isolation Transformer to provide power conditioning, back-up power protection, and power distribution for the critical load.
- 2.13 The bidder should provide and install Power Distribution Panel (PDP) for the new and existing equipment. However, it is advisable to the bidders to visit the site for their assessment of existing facilities before bidding.
- 2.14 Assorted items required for the project like inter connecting copper power supply cables with copper connectors/thimbles (Flat/bottle type) etc. from output of the Isolation Transformer to AVR, from output of AVR to Input of UPS, from output of UPS to UPS SDB panel and inter connecting cables of various change over switches of mains and battery bank etc. are also to be provided by the successful bidder.

Himanshu C
06.08.2024

Roll

13/8/24

3. Work Experience for Vendor and OEM

3.1 Work Experience for Selection of the vendor:-

3.1.1 Bidder must have his local office/authorized representative/dealer in India for after sales service support.

3.1.2 The Bidder shall have to meet the following Work experience:-

Work Experience- (Self - certified with relevant documents*)-	One Similar work** of minimum value of 80% of estimated cost of the project. or Two Similar works** each of minimum value of 60% of the estimated cost of project. or Three Similar works** each of minimum value of 40% of the estimated cost of project.
---	--

Note:

- a) * *Self-certified with Relevant document* means to provide copies of work order/orders clearly mentioning the cost of the project/projects and Receipt Certificate/successful completion certificate/Factory dispatch document/Delivery Challan/Copy of Invoice of the project/projects to various organizations along with the bid.
- b) ***Similar works means* Supply and/or services related to any or combination of the following (in any past ten financial years during the period from FYs 2011-12 to 2023-24) :
- (1) SITC of Earth Station, (2) Teleport installation, (3) Providing Services of Teleport/VSAT/ DSNG, (4) SITC of DTT/ DVB-C/ VSAT/ IT Based Broadcasting Equipment, (5) SITC of DSNG.

Similar Work may be executed with any Central and State Government agency, PSUs, Private organizations. Bidder should provide all the self-certified relevant documents of such work experience along with their cost in Rupees as per Annexure-VI of Appendix-D.

3.2 Work Experience for OEM of Professional IRD and Encoder

3.2.1 Bidder shall offer Professional IRDs and Encoders of only those OEMs who are having past experience of at least five financial years of manufacturing and supplying of similar Professional IRDs and Encoders. List of past supply records of OEM of such equipment to various organizations must be provided.

3.2.2 OEM of the offered equipment must have manufactured and supplied the offered equipment to the leading broadcaster as mentioned in the table below in any five financial years during the period from FYs 2016-17 to 2023-24.

S. No.	Offered Equipment	Quantity
1	Professional IRDs	100 Nos.
2	Encoder	100 Nos.

3.2.3 Copies of supply order and receipt certificate/Factory dispatch document/delivery challan/Copy of invoice in respect of above said quantity of professional IRDs and Encoders provided in para 3.2.2 in any five financial years during the period from FYs 2016-17 to 2023-24 to various organizations should essentially be submitted along with the bid document.

3.3 Work Experience for OEM of Satellite Modulator

3.3.1 Bidder shall offer Satellite Modulator of only those OEMs who are having past experience of at least five financial years of manufacturing and supplying of similar Satellite Modulator. List of past supply record of OEM of such equipment to various organizations must be provided.

3.3.2 OEM of the offered equipment must have manufactured and supplied the offered equipment to the leading broadcaster as mentioned in the table below in any five financial years during the period from FYs 2016-17 to 2023-24.

S. No.	Offered Equipment	Quantity
1	Satellite Modulator	25 Nos.

3.3.3 Copies of supply order and receipt certificate/Factory dispatch document/delivery challan/Copy of invoice in respect of above said quantity of professional IRDs and Encoders provided in para 3.3.2 in any five financial years during the period from FYs 2016-17 to 2023-24 to various organizations should essentially be submitted along with the bid document.

3.4 Work Experience for OEM of 2x20KVA UPS System

Bidders shall offer UPS system of only those OEMs who are having past Experience of:

3.4.1 At least five financial years of manufacturing and supplying 20 KVA or higher rating of ON LINE UPS system for critical load like 24x7 operation of transmission, Data Centre, Earth Station etc. The bidder shall submit documentary evidence in this regard. The list of such supply record of OEM of UPS system to various organizations in proceeding past five years must also be provided.

3.4.2 OEM of the offered equipment must have manufactured and supplied at least 10 numbers of offered 20 KVA UPS system for critical load like 24x7 operation of transmission, Data Centre, Earth Station etc in any five financial years during the period from FYs 2016-17 to 2023-24.

3.4.3 Copies of supply order and receipt certificate of 10 (ten) nos. 20 KVA or higher rating UPS system provided in any five financial years during the period from FYs 2016-17 to 2023-24 should essentially be submitted along with the bid document.

3.5 In addition to above said technical eligibility criteria, Vender/bidder shall also see and ensure to meet the commercial and Financial eligibility criteria pertaining to the a) company existence, b) Annual turnover/Net worth, c) Positive net worth/Profitability, d) Non-Blacklisting certificate, e) ISO certification (If required), f) GFR

Handwritten signature
06.09.2024

Handwritten signature

Handwritten signature

restrictions/Norms (if required), g) PMA and h) relaxation for Start-up as mentioned in the Appendix A, Appendix B & Appendix C of the bid document.

3.6 For Consortium/Joint Venture (If applicable):

In case of Consortium/Joint Venture, Vender/bidder shall follow the instructions provided at Appendix-A of the bid document.

4. Turnkey Implementation and Commissioning

- 4.1 The complete project will consist of Supply, Installation, Testing and Commissioning (SITC) of the Equipment of Earth Stations at DDK Itanagar, Agartala, Kohima, Imphal, Gangtok and Port Blair as detailed at Clause No. 2. Scope of Work. The project will be carried out on a turnkey basis.
- 4.2 The bidder has to integrate, test and commission newly supplied 2x(1+1) Compression System, 2x(1+1) Modulator system, Monitoring System and Power Supply System with the existing earth station equipment and operate the earth Station in 2x(1+1) Configuration.
- 4.3 The bidder has to comply with BIS (Bureau of Indian Standard) certification on invoice to all the offered equipment.
- 4.4 The transition period for shifting/ integration and commissioning with existing equipment is likely to take 5 working days.
- 4.5 Each and every offered equipment and accessories including software should be from a reputed manufacturer and the quoted model should be of high-class, high MTBF, field proven and in use by leading broadcasters/organizations.
- 4.6 The bidder shall submit only one solution (Single BOM) for the offered system. Bid with multiple options against any requirement is liable to be rejected. BOM shall not contain any alternative item for any line entry item. However, bidder can offer additional accessory items as options for performance improvement of main line entry item of same make.
- 4.7 The bidder must ensure completeness of the offered system in all respects. The system should be completed and fully wired for all the indoor equipment fitted in 19" standard racks. The offered system must have enough flexibility in adapting the changing requirements from the technical and operational point of view. The bidder should submit detailed schematics and layouts for proposed solution based on the offered equipment along with the offer.
In order to ensure the completeness of the system, any additional equipment/accessories which bidder feels necessary to complete the configuration should also be quoted. However, in such case they should provide proper justification for the additional equipment required.
- 4.8 As an SITC contract, all supplied equipment are to be installed, tested and commissioned at site as mentioned at Clause 4.1 by the Bidder. The cost of any other

Handwritten signature and date
06/03/2024

Handwritten signature

Handwritten signature

- interconnecting material and labour required for laying of cables, Earthing, earth pits etc. should be included in the offer.
- 4.9 Cost of any other work, consultancy and material required to complete the installation & commissioning of the earth station should be taken into account and clearly mentioned while submitting the bid.
 - 4.10 The bidders are required to submit the proposed system design including Baseband chain, Compression Chain, IF Chain, Layout drawing, rack layout drawing, Power Supply schematic etc. along with the bid. Drawing for the complete 2x(1+1) Earth Station shall also be provided.
 - 4.11 The successful bidder will be required to prepare and submit the final system design as per the site condition in consultation with Doordarshan and get it approved by Directorate General, Doordarshan before actual implementation.
 - 4.12 The bidder will be required to use only high quality HD-SDI video and audio cables, connectors and other accessories from reputed manufacturers. Suitable length of Video cable with matching connectors and Audio cable with matching XLR connectors should be used for rack wiring and long distance applications.
 - 4.13 All video sources will be routed through HD video patch panels. Only high quality 32 HD video patch panels with data rate support up to 3.0 GHz & 20 dB return loss should be offered. The patch panels should be 75 ohm normal through type.
 - 4.14 The offer should clearly specify the list of equipment hardware, interfaces, cables etc and associated software provided with the Remote Computer System for interfacing it with different components of the chain.
 - 4.15 All interconnecting material including cables and connectors shall be provided by the successful bidder to complete the project.
 - 4.16 The successful bidder will be required to print and display the final laminated Technical Block diagram and detailed Line diagrams (in colour) of adequate size for Baseband, Compression, RF, monitoring and Power Supply chain in the facility after the completion of the installation. One set shall be mounted on wall and other for record at Station. The soft editable copy of the Technical Block diagram and detailed Line diagrams (in color) shall also be provided.
 - 4.17 The offer should be complete in all respect.
 - 4.18 Any other work and material required to complete the scope of work must be provided by the bidder.
 - 4.19 The successful bidder must submit the firm's self-certified copies of import license at the time of commissioning in respect of RF Equipment for issuance of operating license from WPC.
 - 4.20 For facilitating maintenance issues, bidder must also submit firm's self-certified copies of Bill of Entry/Custom Invoice of all imported items to DG: DD for release of PBG.

J. Himanshu Kumar
06.08.2024

[Signature]

[Signature]

4.21 All invoices shall bear Serial Numbers of the equipment to meet the requirement of WPC.

4.22 The successful bidder will be responsible for providing after sales service support of all the offered equipment for Seven years from the date of commissioning including five (5) years warranty period. The bidder must submit undertaking for providing after sales support for additional Two (2) years after the end of warranty period along with bid.

If bidder is not the OEM of the offered equipment, then after sales service support for the repairs/ maintenance for 5 years warranty period and for 2 years after the completion of guarantee/ warrantee period shall also be provided either by the OEM directly or through their authorised service . A certificate, on the letterhead, in this regard duly signed by the OEM must be submitted with offer by the bidder.

4.23 The local office/authorized representative/dealer will be nodal point for resolving issues, related to installation, commissioning and after sales service support. Details of OEM office and its location are to be provided along with bid.

4.24 If required, bidder may have to give a presentation to explain their technical offer within one week from the date of issue of letter as part of technical evaluation.

4.25 In the process of technical evaluation Doordarshan can ask for any clarification/ query as required through e-mail/FAX/Post etc, which shall be treated as a part of tender and invariably attended and replied by the bidder within the time stipulated therein.

4.26 Bidder may have to demonstrate (within 15 days) the features of equipment offered as and when asked as part of technical evaluation of Tender. However it will not bestow any right of acceptance of the bid.

4.27 Cross reference in respect of supporting documents, should be given with proper page number and volume no. etc. If required Doordarshan may also ask for any other supporting document to ascertain the claim of the bidder and their OEM.

4.28 To avoid any delay due to inter dependent activities like site readiness, providing power supply etc., the bidder should submit a time frame for completing the activities up to the commissioning of the set-up on a bar chart starting from the date of issue of Purchase Order (P. O.) (i.e. dd/mm/yyyy)+.

4.29 All software being offered, are to be licensed to Doordarshan on perpetual basis without specifying any time limit or without specifying any end of life of the software. Software upgrades within the warranty period will have to be supplied free of cost.

4.30 The bidder may visit the site before the submission of the bid. The bidder may also ensure the soil composition, moisture content, and temperature etc. for earth resistance measurements. The bidder desiring to visit the site must submit the request one week in advance with the details of the persons. All visits will take place only during working days from 1500 to 1700 hours only.

[Handwritten signature]
06.08.2019

[Handwritten signature]

[Handwritten signature]

5. Technical Specifications of Major Equipment

5.1 Specification for Digital Video Distribution Amplifier, Analog Audio & SD/HD-SDI Video Embedder, De-Embedder, and Optical Fiber Link from MSR to Earth Station.

Digital Video Distribution Amplifier, Analog Audio & SD/HD-SDI Video Embedder, De-embedder, and Optical Fiber Link are envisaged to be used for processing the input signal and then fed to HD/SD-SDI router through Patch Panel. The Audio Video processing equipments consists of following equipment:

- A. Digital Video Distribution Amplifier (DVDA)
- B. Analog Audio & SDI Video Multiplexer Unit (Embedder)
- C. Analog Audio & SDI Video De-multiplexer unit (De-embedder)
- D. 19" Rack Frame mounting with hot swappable redundant power supply unit to hold minimum 10 nos. of different cards
- E. Optical Fiber Link for SD&HD SDI with embedded audio signal

5.1.1 General Features for Embedder, De-embedder, Distribution Amplifier and Rack Frame:

- (a) In order to keep the symmetry and to maintain inter-changeability, all the items must be from same manufacturer. Items from different manufacturers will not be acceptable.
- (b) The offered Embedder, De-embedder and Digital Video Distribution Amplifier shall be modular in construction and card type. It should be offered along with the 19" Rack Frame/ housing with hot swappable redundant power supply unit.

(i) Digital Video Distribution Amplifier (DVDA)

A. General

- 1) It should provide automatic equalized output.
- 2) The offered product should auto detect the defined standard of video input signal.
- 3) Monitoring software should allow management of all the signal paths.
- 4) It should ensure no cross channel loading effects.
- 5) Visual indicators should also give its status about power supply, input etc

B. Technical Specifications

S. No.	Parameter	Performance
1	Input	1 x HD/SD- SDI, BNC
2	Output	7 or more x HD/SD- SDI, BNC
3	Processing	
	i) Input Equalisation	Minimum 100 m @1.5 Gb/s & minimum 300m @270 Mb/s
	ii) Return Loss	>15 dB up to 1.5 Gb/s

(ii) Analog Audio & SDI Video Multiplexer Unit (Embedder)**A. General**

- 1) The offered product should auto detect the defined standard of video input signal.
- 2) It should be able to provide programmable audio delay for lip sync issues.
- 3) The offered Embedder should have excellent performance features like "high Input impedance", "flat frequency response", "very low total harmonic distortion" and "extremely high signal to noise ratio (S/N)".
- 4) It should be able to remove all available audio before embedding or allow overwriting with channel shuffling.
- 5) It should be able to provide high quality cable equalization to the input signal up to the length of minimum 100 m @1.5 Gb/s & 300m @270 Mb/s.
- 6) Monitoring software should allow configuration and status of the card.
- 7) Visual indicators should also give its status about power supply, input etc.

B. Technical Specifications

S. No.	Parameter	Performance
(a)	Input:	
i.	Analog Audio Inputs	4 or more analog balanced audio with high input impedance >10 K Ω and maximum inputs level of +24 dBu
ii.	Serial digital video Input	1 no. HD/SD-SDI
(b)	Output:	
i.	No. of Outputs	1 or more HD/SD-SDI signal with Embedded audio
(c)	Processing:	
i.	Audio processing	24 bits or more, 48 kHz sampling
ii.	Audio Frequency Response	± 0.1 dB (20 Hz to 20KHz) or better
iii.	THD (Audio)	< 0.005% (20 Hz to 20KHz) or better
iv.	Channel phase difference	$\pm 1^\circ$ or better
v.	Audio Delay	Equal to Video Delay
vi.	Serial input & output return loss	> 15 dB up to 1.5 GHz

(iii) Analog Audio and SDI Video De-multiplexer unit (De-Embedder)**A. General**

- 1) The offered product should auto detect the defined standard of video input signal.
- 2) It should be able to provide audio delay for lip sync issues.
- 3) It should give balanced audio output with low impedance.
- 4) It should be able provide high quality cable equalization to the input signal up to the length of Minimum 100 m @1.5 Gb/s & 300m @270 Mb/s.

- 5) Monitoring software should allow configuration and status of the card.
- 6) Visual indicators should also give its status about power supply, input etc.

B. Technical Specifications

S. No.	Parameter	Performance
(a)	Input	
i.	Input	1 or more HD/SD-SDI SDI signal
(b)	Output:	
i.	SDI Video Outputs	1 or more
ii.	Analog Audio Outputs	4 or more balanced output
(c)	Processing:	
i.	Audio processing	24 bits or more, 48 kHz sampling
ii.	Audio Frequency Response	<±0.1 dB (20 Hz to 20KHz) or better
iii.	S/N Ratio	>90 dB
iv.	Cross talk	<-80 dB (20 Hz to 20KHz) or better
v.	Audio Signal Level	+22dBm on 600 Ω or better
vi.	Serial input & output return loss	> 15 dB up to 1.5 GHz

(iv) Rack Frame

A. General

- 1) The offered product should have redundant hot swappable power supply.
- 2) It should be capable of monitoring the performance of individual module/card by using SNMP or any other industry accepted interface.
- 3) It should be possible to adjust parameters of individual module/card mounted in the rack frame from a remote PC or any other similar device.
- 4) Standard 19 inches Rack Mounting frame/ housing to hold minimum 10 different cards with hot swappable redundant power supply unit

B. Technical Specifications

S. No.	Parameter	Performance
1.	Control	RS-422 or RJ-45
2.	Operating temperature	5° to 40° Celsius
3.	Mount	Standard 19 inches Rack Mounting frame/ housing
4.	Number of slots	10 or more slots to hold different peripheral cards
5.	Height of frame	3 RU maximum
6.	Power Supply	230±5% Volts, 50 Hz

Himanshu
06-06-2024

L-11

11/10

5.1.2 General Features for Optical Fiber Link:

- (a) The offered solution should be scalable and modular in design and architecture.
- (b) The system should have built-in 1:1 dual redundant & hot-swappable power supply units.
- (c) The SD&HD SDI optical transmitter & receiver modules should have facility to pass 4 stereo/4 AES embedded audio, Dolby E audio etc without any limitation or upgradation by way of hardware or software licenses.
- (d) Trans & Receive unit shall be configurable locally through front-panel or remotely via Web-Interface (Web-GUI, SNMP etc).

(i) Optical Fiber Transmitter (SD & HD SDI with embedded Audio to optical fiber conversion):

S. No.	Parameter	Specification
Input Parameter		
1.	Input type	SD & HD-SDI with 4 stereo/4 AES embedded audio
2.	Standard	SMPTE 292 M & SMPTE 259-M
3.	Input impedance	75 Ohm
4.	Input Connector type	BNC Type
5.	No. of Input	1-No.
6.	Cable Equalization	75m @1.485 Gbps & 300m @270 Mbps for Belden 1694A cable
7.	Return loss	> -14dB @1.485 Gbps
Output parameters		
8.	Output type	One Optical SMPTE297-2006 or latest One SD & HD- SDI SMPTE-259M & 292M
9.	SDI output connectors	BNC
10.	No. of SDI connector	Min. 1
11.	Optical output connectors	SC/PC or LC
12.	No. of Optical connector	Min 1
13.	Operating wavelength	1310 nm OR 1550 nm
14.	Optical power	-8 dBm (min)
15.	Mode	Single mode or Multimode

(ii) Optical Fiber Receiver (Optical fiber to SD & HD SDI with embedded audio conversion) :

S. No.	Parameter	Specification
Input parameter		
1.	Input type	One Optical SMPTE297-2006 or latest
2.	Optical input connectors	SC/PC or LC
3.	No. of Optical connector	Min 1

4.	Operating wavelength	1270 nm to 1610nm
5.	Mode	Single or Multi mode
6.	Optical input level	-18 dBm or better
Output Parameters		
7.	Output Type	SD & HD-SDI with 4 stereo/4 AES embedded audio
8.	Standard	SMPTE 292 M & SMPTE 259-M
9.	Output impedance	75 Ohm
10.	Connector Type	BNC
11.	No. of Output	2 No
12.	Return loss	> -14dB @1.485 Gbps

(iii) **SD&HD-SDI to fiber optical transmitter & receiver link (Chasis):**

S. No.	Parameter	Specification
1.	Size/Dimensions (per chassis)	Max. 3RU / 19" rack-mount
2.	Capacity	Min. 8 slots
3.	Power-supply	1:1 dual redundant (hot-swappable)
4.	Control	Front panel or remotely via Ethernet Interface (Web-GUI, SNMP etc.)

5.2 Technical Specifications for Equipment of Compression and IF System:

The Compression and IF system consists of the following:

- A. HD/SD-SDI/ASI router
- B. Encoders in 2x(1+1) redundant configuration
- C. Modulators in 2x(1+1) redundant configuration
- D. IF Redundancy switch
- E. 1:4 IF Splitter

The base band SDI signals received directly from MSR/PCR to the patch panel through Digital Distribution Amplifiers/Embedder then from patch panel to input of HD/SD-SDI/ASI router, from output of HD/SD-SDI/ASI router to patch panel and finally from patch panel to input of the offered encoders in 2x(1+1) configuration. Output of 1st pair of the offered encoders will be connected to input of the 1st pair of modulators in 1+1 redundancy configuration and output of 2nd pair of the offered encoders will be connected to input of the 2nd pair of the offered modulators in 1+1 redundancy configuration.

5.2.1 HD/SD-SDI/ASI Routing Switcher

A. General

32x32 HD/SD-SDI/ASI Routing switcher should be very reliable and able to be used for selection of any one of the 32 HD/SD-SDI/ASI input signals to 32 different destinations. The equipment offered should be for 24x7 hours use in Broadcast applications. The router has to be quoted with XY and single bus control panels.

Handwritten signature
06.03.2024

Handwritten signature

Handwritten signature

B. Essential features

- i. The routing switcher electronics should be capable of being mounted in a standard 19" rack frame.
- ii. The routing switcher shall handle HD/SD-SDI/ASI signal for routing from input to output destinations. The switching should take place during the vertical interval period.
- iii. The routing switcher shall have facility to pass SD-SDI & SD-SDI with embedded audio, HD-SDI & HD-SDI with embedded audio (including Dolby Digital (AC-3) 5.1, Dolby digital plus 5.1 & Dolby E audio) and ASI signal for routing from input to output destinations of their respective port.
- iv. The routing switcher should have storage facilities for control information, so that in case of power supply failure, the status of the switcher output should remain unchanged after the power supply is restored.
- v. The routing switcher should have auto-switchable dual redundant power supplies.
- vi. The routing switcher quoted against this specification should be complete in all respect and should have the desired features.
- vii. Any of the 32 HD-SDI and SD-SDI input shall be capable of being switched to any or all of 32 outputs port.
- viii. All the requisite drivers, softwares and licenses required for meeting the DD specifications must necessarily be pre-loaded and configured by the OEM before supplying equipment to DD.

C. Technical Specifications

i)	Matrix size	32 HD/SD-SDI/ ASI inputs. 32 destinations (output buses) output HD/SD-SDI/ASI
ii)	Input	SDI (75 ohms, BNC Female either directly mounted on chassis or with suitable adopter) SMPTE 259-M, SMPTE 292M, MPEG-2 TS over DVB ASI
iii)	Equalization for SD-SDI signal	Automatic: 150 Meters at 270 Mbps,
iv)	Equalization for HD-SDI signal	Automatic: 80 Meter at 1.485 Gbps
v)	Output	One or more HD-SDI with embedded audio (including Dolby AC-3 5.1 audio & Dolby E) and SD-SDI with embedded audio for each of 32 HD & SD SDI destinations: (75 ohms, BNC Female either directly mounted on chassis or with suitable adopter)
vi)	Return Loss	≥10 dB on data rate upto 1485 Mb/s throughout the switching chain.

5.2.2 SDTV Encoder in MPEG-2 & H.264/MPEG-4 AVC compression and HDTV Encoder in H.264/MPEG-4 AVC compression configuration with 4:2:0 & 4:2:2 format for both SDTV & HDTV.

A. Essential Features:

- (i) The offered encoder should be a standalone unit having capability of MPEG-2 and H.264/MPEG-4 AVC compression with easy to use either front panel control through front panel keys and front panel display or through web browser.
- (ii) The offered encoder Chassis should have single hardware encoder. There should be dual redundant power supply units per Chassis. These encoder chassis shall be configurable to operate in (1+1) redundant mode without any limitation or requiring upgradation/downgrading by way of Hardware and Software.
- (iii) It should also have the preprocessing hardware and software facility for the efficient encoding process viz; adaptive noise reduction.
- (iv) The encoder should have facility to support BISS -1 and BISS-E encryption mode. The hardware and software for encryption should be provided in all the encoders.
- (v) The encoder should have facility to support internal multiplexing of external ASI input signal on BNC. All the hardware and software including provision for accepting ASI input for multiplexing should be provided in all the encoders.
- (vi) It should have multi-pass encoding hardware and software.
- (vii) It should have interface for Remote Control.
- (viii) It should have facility for PSI generation.
- (ix) On loss of Video input, it should have option to auto switch to either last freeze frame or pre-recorded video frame/test Pattern (format JPEG/PNG or GIF). There should however be a facility to configure the encoder for NO output on the loss of video input.
- (x) The encoder shall be MPEG-2 and MPEG-4 AVC standard compliant without any limitation or up-gradation by way of hardware or software licenses.
- (xi) It should have either front panel display or Keys for configuration of various parameters of encoder or through web browser.
- (xii) There shall have facility for 4 stereo/4 AES audio with MPEG-1 Layer-II & HE AAC v1 & v2 5.1 Audio encoding in each encoder. There should also be provision for Dolby Digital (AC-3) 5.1 decoding in each encoder and encoding audio in Dolby Digital (AC-3) 5.1 & Dolby Digital Plus 5.1 audio along with down-mix of one MPEG-1 Layer-II at any given point of time.
- (xiii) The Encoder shall have audio loudness control for maintaining uniform audio level in spite of changes from different input feeds and programs meeting the ITU-BS-1770-2/ITU-BS-1770-3 standard for loudness control.
- (xiv) The Encoder shall have facility for ancillary data like closed captioning with EIA 608/708, DVB-subtitling, audio descriptor and digital program insertion compliant with SCTE-35 insertion via SCTE-104 triggers without any limitation or up-gradation by way of hardware or software licenses & keys.
- (xv) There should have facility to insert ancillary data through IP data port.

J. V. Sankar
06.08.2024

[Signature]

[Signature]

- (xvi) The output of chassis should be MPEG-2 TS over IP on RJ-45 connector and MPEG-2 TS on BNC connector either directly mounted on Chassis or with suitable adopter.
- (xvii) The Encoder should have facility to insert Dynamic Logo for each channel.
- (xviii) In case of failure of main/redundant encoder chain, audio/visual alarm should be generated to indicate the failure of main/ redundant encoder chain.
- (xix) The encoder should be capable of generating alarm and control signal on GPI port for compression chain redundancy and IF redundancy which shall be controlled by the IF redundancy switch.
- (xx) The encoder should support 10 bit encoding in 4:2:2 mode for better video quality.

B. Video Inputs

- (i) The Encoder shall be capable of accepting HD/SD-SDI and HD/SD-SDI with embedded audio Inputs with a facility to select between different inputs either through front panel keys or through browser on remote computer.

C. Serial Digital Input Specifications

S. No.	Parameters	Specification
1	Video Inputs	SD-SDI & HD-SDI with embedded audio
2	Serial Interface	i) SMPTE 292M/299M, 1485 Mb/s (10 bit) with embedded audio. ii) SMPTE 259M/272M, 270 Mb/s (10 bit) with embedded audio.
3	Format	ITU(R)-BT 601 & ITU-R BT.709
4	Connector	BNC/HD BNC/Micro BNC/DIN/Mini DIN Female, 75 ohm
5	Input Level	800 mV p-p nominal +/- 10%
6	Return Loss	≥15 dB from 5 MHz - 1.5 GHz/ or ≥10 dB on data rate upto 1485 Mbps

D. TS Inputs Specifications for Re-Muxing in Output:

S. No.	Parameter	Specification
A	IP Input	
1	Type	Gigabit Ethernet
2	MPEG Format	MPEG-2 TS over IP (SPTS & MPTS)
3	No. of Bi-directional physical ports dedicated for IP Data Input	Minimum 1 no.
4	IP Data Port Speed	1000 Mbps or better per port
5	Ethernet IP Connector type	RJ45
B	ASI Input	
1	Format	MPEG-2 TS over ASI on BNC

2	Quantity for ASI Input	Minimum 1 no. on BNC/HD BNC/Micro BNC/DIN/Mini DIN Female,75 ohm
3	Speed	Minimum 100 Mbps

E. Video Compression Parameters

S. No.	Parameters	Specification
1	Video Resolutions (PAL)	For SDTV : 720 x 576, 544 x 576, 480 x 576 For HDTV : 1920 x 1080, 1440 X 1080
2	Profiles and Levels	SD MPEG-2 MP@ML, 4:2:0, 8 bit i) SD MPEG-2 Hi422P@ML, 4:2:2, 8 bit ii) SD H.264 MP@L3.0/Hip@L3.0 4:2:0, 8 bit iii) SD H.264 Hi422P@L3.0/Hi422PL3.1, 4:2:2, 8 bit iv) SD H.264 Hi4:2:2P@L3.1, 4:2:2, 10 bit v) HD H.264 HIP@L4.0, 4:2:0, 8 bit vi) HD H.264 Hi422P@L4.0 / Hi422P@L4.1 4:2:2, 10 bit
3	Video Bit-rate	1.5 to 20 Mbps for SD MPEG 2 4:2:2 profile depending upon Resolution 1.5 to 15 Mbps for SD MPEG 2 4:2:0 profile depending upon Resolution 1.0 to 12.5 Mbps for SD MPEG 4 4:2:0 profile depending upon Resolution 1.0 to 25 Mbps for SD MPEG 4 4:2:2, profile depending upon Resolution 3.0 to 20 Mbps for HD MPEG 4 4:2:0, profile depending upon Resolution 3.0 to 80 Mbps for HD MPEG 4 4:2:2, profile depending upon Resolution
4	Temporal Processing	Dynamic GOP structure support such as IP,IBP,IBBP,IBBBP etc.
5	Coding of Interlaced Video	Adaptive field & frame Processing support
6	Spatial Redundancy	Discrete Cosine Transform (DCT) Reduction
7	Chrominance Format	4:2:2 and 4:2:0 for SDTV and HDTV
8	Aspect Ratio	4:3 and 16:9

F. Embedded Serial Digital Audio Input specifications

S. No.	Parameters	Specification
--------	------------	---------------

Handwritten signature
06.08.2024

Handwritten signature

Handwritten signature

1	Serial Interface	SMPTE 272M, SMPTE 299 M, 1485 Mbps, 270 Mbps (20 bit)
2	Format	AES/EBU, 8 channels
3	Connector	BNC/HD BNC/Micro BNC/DIN/Mini DIN Female,75 ohm

G. Audio Compression Technique

S. No.	Parameters	Specification
1	Audio Encoding Method	i) MPEG-1 layer II ii) HE AAC(MPEG 4)v1 & v2 5.1 audio iii) Dolby Digital 5.1 AC-3 audio iv) Dolby Digital Plus 5.1 E-AC-3 audio
2	Audio decoding Method	Dolby Digital 5.1 AC-3 audio Dolby Digital Plus 5.1 audio Dolby E
3	Audio Pass through	Dolby Digital 5.1 AC-3 audio Dolby AC-3 digital plus 5.1 AC-3 audio Dolby E Linear PCM
4	Data rate	i) 64-192 kbps (MPEG-1, layer II) ii) 32-72 kbps (MPEG-4, HE AAC v1 audio encoding) iii) 16-48 kbps (MPEG-4, HE AAC v2 audio encoding) iv) 224-640kbit/s (Dolby Digital 5.1 audio encoding) v)192-640kbit/s (Dolby Digital Plus 5.1 audio encoding)

H. Encoder Output

S. No.	Parameter	Specification
1	Format	MPEG-2 TS over IP
1(a)	No. of Bi-directional physical ports dedicated for IP output	Minimum 1 no. per chassis
1(b)	IP Data Port Speed	1000 Mbps or better per port
1(c)	Ethernet Connector Type	RJ 45
2	Format	MPEG-2 TS/DVB-ASI
2(a)	Output	2 no per chassis (min)
2(b)	Speed	Minimum 100 Mbps
2(c)	Connector Type	BNC/HD BNC/Micro BNC/DIN/Mini DIN Female,75 ohm

I. Control (for remote access and monitoring)

S. No.	Parameter	Specification
1	Control port for remote access and monitoring	Min. 1 no. 10/100/1000 Base-T Ethernet port (RJ 45)

J. Min...
06.09.2024

[Signature]

[Signature]

J. Hardware of Server in case of software compression solution

A) General Feature:

- i. CPU/Chipset of server should have facility to enable an environment where applications can run within their own space, protected from all other software on the system.
- ii. CPU/Chipset of server should have security feature that can reduce exposure to viruses and malicious-code attacks and prevent harmful software from executing and propagating on the server or network.
- iii. CPU/Chipset of server should have facility of Secure Key consisting of a digital random number generator that creates truly random numbers to strengthen encryption algorithms.
- iv. CPU/Chipset of server should have Thermal Monitoring facility to protect the processor package and the system from thermal failure.
- v. The offered processor of server should be scalable, high quality, robust with efficient performance.
- vi. Each server of software compression solution should be designed with 85 percent (Max.) CPU loading.
- vii. CPU of server shall be similar to Intel Xeon Gold series / AMD EPYC 3rd Generation Series or better and the launch date of CPU of offered server should not be prior to year 2021.

B) Hardware Feature:

S. No.	Parameter	Specification
A	Performance of Central Processing Unit	
1	No. of Core	18 (Min.) per CPU
2	No. of Thread	36 (Min.) per CPU
3	Processor Base Frequency	2.10 GHz or better
4	No. of CPU	One or more
B	Memory Specification	
5	RAM	DDR4, 64 GB or more
6	Storage Memory	SSD, 240 GB (Min.) in Raid 1 Configuration
C	Operating System	
7	Operating system	Linux
D	Ethernet Network	
8	No. of Ports (Duplex) in server	i) Two nos. of 1 Gigabit port for Input or more ii) Two nos. of 1 Gigabit port for Output or more iii) Two nos. of 1 Gigabit port for Management & Control iv) Two nos. of 1 Gigabit port for Ancillary services
E	PCI slot	
9	PCI slot	2 nos. or more

Handwritten signature
06.03.2024

Handwritten mark

Handwritten mark

F	Operating Environment	
10	Operating Temperature	+10 to +35 °C
11	Humidity	10% to 90% non-condensing

5.2.3 Satellite Modulator

a) Essential Features:

- i) The offered modulator should be compact, reliable and have state of the art technology.
- ii) It should provide IF output (70 + 18 MHz) as per DVB-S and DVB-S2 standards' modulation schemes based on the user requirement.
- iii) It should have facility to perform pre-equalization/pre-correction to signal before feeding upconverter so that downlink signal is kept within 36 MHz BW of the transponder. This should not affect the operation of the existing IRDs (MPEG-2, MPEG-4, HEVC and DVB-S & DVB-S2 compliant).
- iv) The offered modulators should have front panel display. It should be possible to configure the modulators through front panel keys and through browser on remote computer.
- v) The offered modulators should be compliant to the ETSI 103 129 DVB Carrier ID (DVB-CID) requirement.
- vi) Modulators will be used in 1+1 redundant mode.
- vii) The redundancy of the offered modulators shall be controlled through the offered IF redundancy switch.
- viii) In case of failure of main/ redundant modulator, audio/visual alarm should be generated to indicate the failure of main/ redundant modulator
- ix) The offered Modulators should have facility to take ASI input through BNC port and MPEG2 TS over IP input through IP data port.
- x) All the requisite drivers, software and licenses required for meeting the DD specifications must necessarily be pre-loaded and configured by the OEM before supplying equipment to DD.

b) Technical Specifications:

S. No.	Parameter	Specifications
I. ASI Inputs		
1	Compliance	DVB Document A010 rev. 1, May 1997: Section 4.4
2	Byte stuffing modes	Byte and single packet burst mode.
3	Connector	BNC
II. IP Input Data Port {External IP to ASI converter is not acceptable.}		
1	Input data format	MPEG-2 TS over IP
2	Ethernet interface	1000 base T
3	Ethernet Connector	1xRJ45

III. Forward Error Correction and Modulation Scheme as per DVB-S standard		
1	Multiplex Adaptation and Energy Dispersal	As per ETSI EN 300 421 (DVB-S)
2	Outer Coding	Reed-Solomon (204,188,T=8)
3	Interleaving Depth	12
4	Inner coding	QPSK : Convolution R=1/2, 2/3, 3/4, 5/6 or 7/8
5	Spectrum Roll off factor	20%, 25 % and 35% selectable
6	Modulation	QPSK
7	Transmission rates	variable, 1.0 to 45.0 M symbol/s. (min.)
IV. Forward Error Correction and Modulation Scheme as per DVB-S2 standard		
1	Multiplex Adaptation and Energy Dispersal	As per EN 302 307 (DVB-S2)
2	Modulation	QPSK, 8PSK
3	Modulation mode	Should be capable of emitting signals on the following mode 1. Backward compatible mode (DVB-S/ DVB-S2 one at a time) 2. Constant Coding and Modulation mode.(CCM)
4	Outer Coding	BCH
5	Inner coding	LDPC R= 1/2, 3/5, 2/3, 3/4, 4/5, 5/6, 8/9, 9/10 (for DVB-S2, QPSK), R= 3/5, 2/3, 3/4, 5/6, 8/9, 9/10 (for DVB-S2, 8PSK)
6	Spectrum Roll off factor	5%, 10%, 15%, 20%, 25% and 35% selectable
7	Transmission rates	Variable, 1.0 to 45 M symbol/sec (min.)
V. IF output Interface Specifications		
1	Output Frequency Range	70 +/- 18 MHz
2	Output Impedance	75 ohms unbalanced
3	Connector	BNC, female
4	Output Return Loss	15 dB (min.)
5	Output Level Range	-20 dBm to 0 dBm
6	Level Step Size	0.2 dB max.
7	Spurious Outputs	≤ -55 dBc/4 kHz at 0 dBm output power level in Band. or ≤ -60 dBm outside Band
8	Synthesizer Phase Noise	IESS-308/309 compliant or better

Himanshu
06.08.2024

SL

SL

9	CW mode	Selectable
10	Noise floor (No/ C)	< -120 dBc/Hz
VI. Internal 10 MHz clock & Synchronization		
1	Frequency stability with respect to temperature	<+2.5ppm over 0°C to 50°C

5.2.4 IF Redundancy switch

IF redundancy switch would be used for the compression chain redundancy in 1+1 configuration for Encoders and Modulators.

a) Essential Features:

- (i) The offered IF redundancy switch must be from the OEM of offered satellite modulator or endorsed/authorised by the OEM of offered satellite modulator to ensure compatibility of the offered IF redundancy switch with the offered modulator system.
- (ii) The switch should be able to accept alarm signal from both main and redundant chain equipments (Encoders and Modulators) for compression chain redundancy.
- (iii) In case of failure of main / redundant chain, audio or visual alarm should be generated to indicate the failure of main/ redundant chain.
- (iv) The offered IF redundancy switch should have dual redundant power supplies.
- (v) Facility for automatic, Manual and remote (through web interface) switching of the modulators should be available through the IF Switch.
- (vi) The switch should have high reliability, robustness and should be of professional type.
- (vii) All the requisite drivers, software and licenses required for meeting the DD specifications must necessarily be pre-loaded and configured by the OEM before supplying equipment to DD.

b) Technical Specifications

S. No.	Parameter	Specifications
i)	Operating frequency range	50 to 90 MHz
ii)	Insertion loss	≤ 3 dB
iii)	Isolation	
	a) Input to input	45dB min
	b) input to output	50dB min
iv)	Input return loss	13 dB min
v)	Output return loss	13 dB min
vi)	IF connector	BNC/ SMA type
vii)	Impedance	75 Ohms
viii)	Remote control	RS232 or RS422/485 or RJ 45

5.3 Technical Specifications for Monitoring and Measuring System:

Monitoring systems for compression and existing uplink chain is envisaged to be provided using HD/SD-SDI/ASI router, IRDs and Audio/Video monitors. The Monitoring System consists of following three parts:

- a) **Input Monitoring:** The input HD/SD-SDI (Audio Embedded) signal coming through digital video cables and OFC link will be monitored with 9" video monitor via HD/SD-SDI/ASI router.
- b) **Downlink Monitoring:** The input signal coming from 7.3 - 7.6 m PDA via LNA and down converter will be routed through existing route of RF Patch panel and fed to IRD (with L band input). The Output of IRD will be monitored with 9" video monitor via HD/SD-SDI/ASI router.
- c) **Confidence Monitoring:** Confidence Monitoring system should have provisions for monitoring outputs from Encoders, Modulators, existing Up-converter and HPAs routed through existing route of RF Patch panel and fed to IRD (with L band and ASI input). The output of IRD will be monitored with 17" video monitor and 8 channel audio bar graph monitoring system via HD/SD-SDI/ASI router.

The technical specifications of some of the major equipment of monitoring measuring systems are given below:

5.3.1 17" Wide Screen Multi-Format LCD-TFT Colour Video Monitor

A. Essential Features:

- i) The offered monitor should incorporate high intensity, high contrast wide screen 17"(nominal), wide viewing angle LCD/TFT/OLED Panel to view stable images from various angles: both horizontally and vertically, with no reduction in picture contrast, brightness and colour saturation.
- ii) The LCD/TFT/OLED panel of the offered monitor should have resolutions of 1920x1080 pixels in 16:9 aspect ratio. The offered monitor should support 16:9 and 4:3 aspect ratios of the video signal. The monitor should also support 1920X1080/50I (HD) and 720X576/50I (SD) video formats.
- iii) LCD/TFT/OLED colour monitor should accept SD and HD SDI input (detected automatically) as well as analog composite video input.
- iv) The offered monitor should support embedded audio. It should also have analogue audio input and built in speaker for audio monitoring.
- v) The offered monitor should have 10-bit signal processing.
- vi) The monitor should have 1:1 pixel mapping to display the pictures in the original resolution (subject to the native resolution of the LCD/TFT/OLED panel) and aspect ratio of the input signal without any stretch and distortion.
- vii) It should be possible for the user to select the industry standard colour temperature through menu for matching colours and gradation of the monitor.
- viii) The LCD/TFT/OLED panel should be coated with Anti-Reflection protection layer to provide high transmission rate of the internal light source and to keep the reflection from ambient light to a minimum.
- ix) The monitor should have an external remote control capability via Ethernet, serial or similar interface.

J. Manoj Kumar
06.08.2024

hd

5/10

- x) The offered monitor should have front panel controls to control the display parameters like brightness, contrast, color saturation etc.
- xi) The offered monitor should be rack mountable and hence necessary 19" mounting brackets should be supplied.

B. Technical Specifications:

S. No.	Parameter	Specification
1.	Display size	17" diagonally (nominal)
2.	Screen type	LCD/TFT/OLED
3.	Resolution	1920 x 1080 pixels or better
4.	Colour reproduction	16 million or better
5.	Contrast ratio	300:1 or better
6.	Viewing Angle	176 degrees in Horizontal & 176 degrees in Vertical or better
7.	Brightness	250 cd/sq.m or better
8.	Supported aspect ratios of video input	16:9 and 4:3 (auto detection)
9.	Video Inputs	(i) HD/ SD SDI: 2 or more HD SDI SMPTE 292, 1.485Gb/s, 0.8V pp across 75 ohms (1080/50I) and SD SDI SMPTE 259 in BNC, 270Mb/s, 0.8V pp across 75 ohms, auto detection (ii) Analog: 1 or more Composite (PAL), 1 V p-p across 75 ohms
10.	Video input connectors	HD/ SD SDI: 2 or more BNC Analog: 1 or more BNC
11.	Analog Audio Inputs	XLR/RCA Jack/Phone Jack/ Mini Jack
12.	Video Format	SD: 720 x 576, 704 x 576, 544 x 576, 480 x 576, 352 x 576 HD: 1920X 1080/50I
13.	Video Outputs	(i) HD/ SD SDI: 1 or more SDI SMPTE 292 in BNC, 1.485Gb/s, 0.8V pp across 75 ohms (1080/50I) or 1 or more SDI SMPTE 259 in BNC, 270Mb/s, 0.8V pp across 75 ohms active loop through of selected input (ii) Analog O/P: 1 or more Composite (PAL) in BNC, 1 V p-p across 75 ohms and Component in BNC across 75 ohms loop through.
14.	Audio Outputs	XLR/RCA Jack/Phone Jack/ Mini Jack and built-in speaker
15.	Control I/O	Serial (RS 232/422/485)/ Ethernet RJ-45

5.3.2 Dual 9" HD/SD-SDI Colour Video Monitor

A. Essential Features:-

- i) The video & audio monitor should have ability to monitor both audio & video from selectable HD/SD-SDI (video & embedded audio) and composite analog video source.
- ii) Analog audio inputs should also be available for use with analog video monitoring.
- iii) Monitor should have LCD/TFT/OLED display of size dual 9" (nominal) diagonal.
- iv) Rack adaptor unit should also be offered for mounting dual 9" video monitors in a standard 19" rack.
- v) It should have audio monitoring along-with bar-graph display facility.
- vi) It should have direct control for brightness, contrast, Colour & input selection.
- vii) It should have low power consumption.

B. Technical Specifications:-

S. No.	Parameters	Specifications
1.	Display Size	9 inch diagonally (Nominal)x2
2.	Screen type	LCD/TFT/OLED
3.	Resolution	1920X1080 or more
4.	Colour reproduction	16 millions or better
5.	Contrast Ratio	750 : 1 or more
6.	Viewing Angle	170 degree horizontal , 170 degree vertical
7.	Brightness	350 cd/m ² min
8.	Aspect Audio	16:9 and 4:3 (auto detection)
9.	Video Inputs	(i) HD/SD SDI: 2 or more in HD/SD-SDI (with embedded audio) in BNC 0.8 V across 75 ohms with loop through output. (ii) Analog: 1 or more Composite (PAL) in BNC, 1V across 75 ohms.
10.	Video input connectors	HD/ SD SDI: 2 or more BNC Analog: 1 or more BNC
11.	Analog Audio Input	XLR/RCA Jack/Phone Jack/ Mini Jack
12.	Video Format	SD: 720 x 576, 704 x 576, 544 x 576,480 x576, 352 x 576 HD: 1920X 1080/50I

Himanshu
06.08.2024

LS

110

13.	Video Outputs	(iii) HD/ SD SDI: 1 or more SDI SMPTE 292 in BNC, 1.485Gb/s, 0.8V pp across 75 ohms (1080/50i) or 1 or more SDI SMPTE 259 in BNC, 270Mb/s, 0.8V pp across 75 ohms active loop through of selected input (iv) Analog O/P: 1 or more Composite (PAL) in BNC, 1 V p-p across 75 ohms and Component in BNC across 75 ohms loop through.
14.	Audio Outputs	XLR/RCA Jack/Phone Jack/ Mini Jack and built-in speaker
15.	Control I/O	Serial (RS 232/422/485)/ Ethernet RJ-45

5.3.3 8 channel Audio Monitor with Bar-graph & internal speakers.

A. Essential Features:

- i) High quality auto sensing 3G/HD/SD-SDI multi-channel audio monitoring system.
- ii) It should have high quality internal stereo loudspeakers.
- iii) 8 channel monitoring with ability to monitor any channel on either speaker, including combinations & groups.
- iv) 53 segment tri-color LED/ Screen bar graph display.
- v) Headphone output with loud speaker mute.
- vi) Dolby E, Dolby Digital 5.1 audio and Dolby Digital Plus 5.1 audio decoding from HD SDI and AES signal sources.
- vii) Multi-channel outputs for external stereo or 5.1 loudspeaker system integration.
- viii) Front panel controls for any combination of up to 8 channels.
- ix) Premium quality drivers and power amplifier.
- x) Excellent frequency response and low distortion.
- xi) It must have premium quality drivers and power amplifiers.
- xii) It should be of professional quality, 19" rack mountable and of reputed make.

B. Technical Specifications:

S. No.	Parameters	Specifications
1.	Inputs	8 Balanced analogue 4 Balanced AES/EBU pairs 4 unbalanced AES pairs 2 HD/SD-SDI
2	Outputs	8 Balanced analogue 4 Balanced AES/EBU pairs 4 unbalanced AES pairs 1 HD/SD-SDI re-clocked

3	Connectors	Analogue : XLR/D-type (with breakout cables for XLR) Balanced AES/EBU : XLR/D-type (with breakout cables for XLR) Unbalanced AES : BNC 75 Ohms 3G/HD/SD-SDI re-clocked : BNC 75 Ohms
4	Computer Interface	RS-485/RS 232/RJ-45
5	Sample rate for Digital input	48KHz
6	Analog O/P	
	a) Frequency Response	± 1 dB (20Hz to 20KHz)
	b) Noise + THD	Better than -60dB w.r.t. max O/P
7	Peak acoustic output at 2 feet	100 dB SPL
8	Mount	19" rack mount

5.3.4 High Quality Digital Audio Ampli-speaker

A. Essential Features:

- i) The offered ampli-speaker should have wide dynamic range, low distortion, flat frequency response and high SPL capability.
- ii) The offered ampli-speaker should have two way speaker system consisting of a woofer and a tweeter. It should be a bi-amplified active monitor system.
- iii) It should have 8" Low Frequency Transducer (woofer) and approximately 1" High Frequency Transducer (tweeter).
- iv) The transducers/ drivers should be magnetically shielded for exceptional transient response and superb power handling. There should be no interference when these ampli-speakers are placed in the close proximity of other audio and video equipment especially CRT-type monitors.
- v) It should incorporate two high power amplifiers to provide 150 Watts (RMS) or more power to the low frequency transducer and 70 Watts (RMS) or more power to the high frequency transducer. These amplifiers should be highly efficient and should withstand long hours of uses.
- vi) It should be equipped with a precise cross-over network for smooth transition between transducers.
- vii) The ampli-speaker should disperse sound across the frequency spectrum evenly and consistently along the horizontal and vertical window of consistency.
- viii) It should be possible to network multiple ampli-speakers to control their various parameters such as volume, equalizers/ filters etc. It should also be possible to calibrate various parameters of the ampli-speaker in accordance with the acoustic environment. Necessary hardware and software required for this purpose must also be included in the offer.
- ix) The ampli-speaker should have volume control arrangements for standalone operations. It should also indicate signal overloading.

J. Dimensha
06.08.2024

let

10/10

- x) The ampli-speaker should employ Digital Signal Processing (DSP).
- xi) The offered ampli-speaker should accept balanced analog audio on 3-pin XLR female connector. It should also accept balanced AES/EBU digital audio input on 3-pin XLR female connector.
- xii) The offered ampli-speaker should be suitable for horizontal and vertical mounting.
- xiii) The offered ampli-speaker should also be capable of ceiling, wall and stand mountings.

B. Technical Specifications:

S. No.	PARAMETER	PERFORMANCE
1	INPUTS	
1.1	Digital Audio Input	AES/EBU, 24 bit, 48 kHz on XLR
1.2	Analogue Audio Input	Balanced on XLR with 10K Ω input impedance
2	DRIVERS	
2.1	Bass (woofer)	8 inch
2.2	Treble (Tweeter)	approx. 1 inch
3	FREQUENCY RESPONSE	
3.1	Lower cutoff frequency	< 40 Hz
3.2	Upper Cutoff Frequency	> 20 KHz
4	AMPLIFIER POWER	
4.1	Bass (woofer)	150 Watts or better
4.2	Treble (tweeter)	70 Watts or better
4.3	Gain	X1, X5 and variable
5	SOUND PRESSURE LEVEL	
5.1	Short term RMS SPL @ 1 Meter	Better than 110 dB
5.2	Continuous Max SPL @ 1 Meter	Better than 100 dB
6	DIMENSION	
6.1	Width	\leq 300 mm
6.2	Height	\leq 450 mm
6.3	Depth	\leq 400 mm
7	NETWORKING	Via RJ 45 port

5.3.5 Integrated Receiver Decoder (IRD)

A. Essential Features :

- i) The professional IRDs should receive ASI and L band input signal and provide analog base band (Video and audio), digital SD-SDI, SD-SDI with Embedded audio, AES/EBU, HD-SDI, HD-SDI with Embedded audio, ASI outputs and MPEG-2 TS over IP output with multiple services filtering facility.
- ii) One SD-SDI down converted output of HD-SDI should be available.
- iii) IRD should be able to carry out multi service filtering on IP output port.
- iv) IRD should have provision to enter or edit all the parameters for perfect reception of the signals either through front control panel display or through web browser.
- v) There should be at least one vacant slot (CI slot) for conditional Access System for descrambling all MPEG-2 & MPEG 4 and DVB-S & DVB S2 services.

Himanshu
22/01/2017

AA

9/10

- vi) There shall be a provision for observing BER & signal level or C/N & C/N margin or Eb/No & Link Margin for DVB-S mode of operation and PER & signal level or C/N & C/N margin or Es/No & Link Margin for DVB-S2 mode of operation either through front control panel display or through web browser.
- vii) IRD should be able to descramble BISS mode 1 and BISS-E signals.
- viii) There should be direct decompression of ASI to SDI i.e. not through analog to Digital conversion.
- ix) IRD should have facility to pass ancillary data like closed captioning, EIA 608/708, DVB-Teletext, DVB- subtitle, DPI SCTE-35 etc.
- x) The IRD should be able to store at least 10 preset configurations in its memory.
- xi) IRD should have facility to decode opportunistic data and pass ancillary data like closed captioning EIA 608/708, DVB-Teletext, DVB- subtitle, DPI SCTE-35 etc.
- xii) It should be possible to configure and monitor the IRD through Control Computer.

B. Technical Specifications:

S. No.	Parameters	Specifications
I. ASI input Parameter		
1	Format	MPEG-2 DVB-ASI
2	Quantity for ASI Input	Minimum one on BNC
II. RF input Parameter		
1	Input Frequency Range	950 - 2150 MHz
2	No. of Inputs	2
3	Tuning Step Size	125 kHz, Max.
4	Satellite Frequency Band	C- Band & Ku-Band, Selectable
5	Input Impedance	75 Ohms
6	Input Connector	F-Type female
7	Input Power Range	-30 to -65 dBm per carrier
8	Image Rejection	>30 dB
9	Input Return Loss	9 dB, Min.
10	Noise Figure	15 dB, Max.
11	AFC Tuning Range	± 5 MHz
12	De-Modulation Method	DVB-S QPSK, DVB-S2 QPSK and 8PSK demodulation
13	Variable Symbol Rates	1.0 to 40 M symbol/sec for DVB-S 1.0 to 40 M symbol/sec for DVB-S2
14	Convolution Inner FEC selectable	R= $\frac{1}{2}$, $\frac{2}{3}$, $\frac{3}{4}$, $\frac{5}{6}$, $\frac{7}{8}$ (DVB-S, QPSK), R= $\frac{1}{2}$, $\frac{3}{5}$, $\frac{2}{3}$, $\frac{3}{4}$, $\frac{4}{5}$, $\frac{5}{6}$, $\frac{8}{9}$, $\frac{9}{10}$ (DVB-S2, QPSK) R= $\frac{3}{5}$, $\frac{2}{3}$, $\frac{3}{4}$, $\frac{5}{6}$, $\frac{8}{9}$, $\frac{9}{10}$ (DVB-S2, 8PSK)
15	IF Filter Bandwidth	Automatic Selection (dependent on Symbol Rate)
III. Audio and Video Decompression Parameters:		

Signature
06.08.2024

ft

2/10

1	Video Resolution (all resolutions shall be capable of I, P & B frame decoding, other standard resolution should be selectable)	For SDTV : 720 x 576, 704 x 576, 544 x 576, 480 x 576 For HDTV : 1920 x 1080, 1440 X1080
2	Video Decompression Type	a) SD MPEG-2 MP@ML, 4:2:0, 8 bit b) SD MPEG-2 Hi422P@ML, 4:2:2, 8 bit c) SD H.264 MP@L3.0/Hip@L3.0 4:2:0, 8 bit d) SD H.264 Hi422P@L3.0/Hi422PL3.1, 4:2:2, 8 bit e) SD H.264 Hi4:2:2P@L3.1, 4:2:2, 10 bit f) HD H.264 HIP@L4.0, 4:2:0, 8 bit g) HD H.264 HI422P@L4.0, HI422P@L4.1, 4:2:2, 10 bit
3	Television Standard	PAL-B (EN50083-9)
4	Audio Decompression Type	i) MPEG-1 Layer-II audio ii) HE AAC (MPEG 4) v1 & v2 5:1 Audio iii) Dolby Digital (AC-3) 5:1 audio iv) Dolby Digital plus 5.1 (E-AC-3) (Pass through) v) Linear PCM (Pass-through) vi) Dolby E (Pass through)
IV. Transport Stream O/P:		
1	Format	i) MPEG-2 TS over ASI on BNC ii) MPEG-2 TS over IP on Ethernet with service filtering facility including opportunistic data.
2	Quantity	i) Minimum one no. on BNC ii) Minimum one no. on RJ 45
V. Video Output Specifications		
1	Connector Type	BNC (75 Ohm)
2	Video Output Format	Composite video, SD-SDI and HD-SDI
3	Video Outputs	Composite video output- One No. HD/SD-SDI Output- Two Nos.
4	Analog Video O/P Level	1.0 V p-p +/- 5%
5	SD-SDI and HD-SDI O/P Serial Interface	SMPTE 292M-1485 Mbps SMPTE 259M-(10 bit) 270 Mbps
6	SD-SDI with Embedded Audio	SMPTE 272M
7	HD-SDI with Embedded Audio	SMPTE 299 M
8	Digital Video O/P Level	800 mV p-p for SDI As per ITU-R BT.601 (part A)
9	Gen lock Input	One
VI. Digital Audio Output Specifications		

Handwritten signature
06.08.2024

Handwritten mark

Handwritten mark

1	Output Format	i) AES/EBU or AES-3 id ii) HE AAC(MPEG 4) v1 & v2 5.1 Audio iii) Dolby Digital (AC-3) 5.1 audio iv) Dolby Digital plus 5.1 (E-AC-3) (Pass through) v) Linear PCM (Pass-through) vi) Dolby E (Pass through)
2	Load Impedance	110 Ohms
3	Connector Type	XLR male Socket or with suitable XLR adapter (i.e. no terminal block)
4	Number of Output	4 Stereo Channels
VII. LNB Power Supply & Control		
1	LNB Voltage	Off, +13 V(Vertical), +18 V(Horizontal)
2	Over Current & Short Circuit protection	Fold back current limiting.
3	LNB Control (Low/High Band)	22 +2 KHz Tone
VIII. Mount		
1	Mount	19" Rack Mount

5.3.6 Mains Distribution Unit (MDU)

a) Essential Features:

Mains Distribution Unit (MDU) shall be installed in the compression system equipment racks to feed power supply to each equipment installed in these racks. It should have sequential delayed output, output status LED, and IEC-3 pins for each equipment. The specifications are detailed below:

b) Technical Specification:

S. No.	Parameter	Specification
i)	No. of fused outlets with IEC 3-Pin Connectors	12 nos. or more
ii)	Primary Power Supply	220/240V AC nominal, single phase, (50 +/- 2) Hz
iii)	Current (Max)	16 Amp
iv)	Operating temp:	-10° C to + 50° C
v)	Relative humidity	85 % non-condensing
vi)	Altitude	Should operate upto 10,000 Feet AMSL

5.3.7 4K/ UHD TV Display Units

S. No.	Features	Specifications for 4K/UHD, size -55 inch or more Display / TV / Panel
1	Display Size	55 inches or above
2	Panel Technology	Inplane Switching (IPS)
3	Native Resolution	3840 x 2160 (UHD) 4K
4	Brightness	400 cd/ m ² or above
5	Contrast Ratio	450000:1 or better

Handwritten signature and date:
25.03.2024

Handwritten signature

Handwritten signature

	(Dynamic)	
6	Viewing Angle	178°x178°
7	Response Time	15 ms or less
8	Maximum Bezel Width (Left/Right/Top /Bottom)	13/13/13/20 mm or less
9	Input Ports	HDMI - 3 Nos., USB 2.0-1 no., RS232C -1 no., RJ45 -1 No., RF-1 No.
10	Output Ports	Optical output-1 for digital audio
11	Special features	Smart Share / Screen Share, Fail over, Wake on LAN, Wireless access point/Hotspot, Pre-loaded You-tube app, Play via URL, SOC Player
12	Wi-Fi	Built-in Wi-fi required
13	Blue-tooth	Yes
14	Audio	20W (10W * 2)
15	Power Supply	100-240V~ 50/60Hz
16	Power Type	Built-in Power
17	Power Consumption	145 W or Less (Typical)
18	Certificates	BIS
19	Accessories	Table stand, Wall mount, Remote, IR remote, user manual
20	OEM Warranty	5 Years

5.4 Technical Specifications for Power Supply System

The Power Supply System consists of UPS, Battery, AVR, Distribution of Supply and Earthing System.

5.4.1 UPS System

5.4.1.1 General Features:

1.	<p>a) The UPS system should be fully DSP controlled in all respects (i.e. rectifier control, inverter control, display, digital diagnostics.), solid-state type, utilizing On Line Double Conversion technology (high frequency PWM using IGBT Rectifier & inverter section)</p> <p>b) The UPS system should be capable of providing continuous high quality sinusoidal waveform power for electronic equipment loads.</p> <p>c) The UPS system should conform to voltage frequency independent technology.</p>
2.	<p>The DSP based controller should have following characteristics:</p> <p>a) Diagnostic monitoring achieved by Fast Fourier Transform (FFT) of spectrum analysis</p> <p>b) Adaptive control by having the speed to monitor and control the system concurrently</p> <p>c) Real time generation of smooth, near optimal reference profiles and move trajectories</p> <p>d) Control power switching and inverters and generate high resolution outputs.</p>

Signature
26-08-2014

Signature

Signature

3.	The UPS should offer low input current harmonic distortion (THDi), good regulation, excellent transient response and high stability.
4.	The UPS system should have a monitoring panel (LCD Based) with various types of fault alarms and metering functions including: a) Output voltage, current & frequency. b) Input voltage, current & frequency. c) Bypass Voltage, Current & frequency. d) Battery capacity, backup time left & bad battery indication. e) Temperature of System, Inverter section and Rectifier section. f) The UPS system should display RMS value of load current. g) The UPS system should have facility to generate aural alarm for bad Battery condition.
5.	a) The UPS system should have wide input voltage and input frequency tolerance as specified in Rectifier section. b) In built Transient Voltage Surge Suppressor (TVSS) should be provided at the input of the UPS System.
6.	The UPS system should have provision for controlling all the three phases individually, even in case of 100% unbalancing at the output with even 0% load on one phase.
7.	In case of failure of parallel operation, automatic and manual override for the system to work in 1+1 hot standby should be available. (Firm should enclose single line diagram of mains changeover panel).
8.	The UPS system should be capable of supplying energy to load from commercial mains without any break in case of phase reversal at the input. It should also generate aural and visual alarm in such a case.
9.	a) The system should have provision of protection for (i) Input under voltage (ii) Input Over Voltage (iii) Output Over Voltage (iv) Output Over load (v) Output short circuit (vi) Battery under Voltage (vii) Over temperature (viii) DC Over current b) The system should generate aural and visual alarms for above-mentioned conditions.
10.	The UPS system should have Controls as (i) Input Circuit Breaker (ii) Bypass Circuit Breaker (iii) Maintenance Bypass Switch (iv) Inverter ON / OFF Switch (v) Alarm acknowledge switch

11.	<p>a) The system should have facility to store the Logs of the events being monitored by monitoring system.</p> <p>b) The UPS system should have the capability to store a minimum of last 100 events.</p> <p>c) The UPS should have in – built digital fault diagnostic through stored events in UPS system.</p>
12.	<p>a) The UPS OEM should specify the nos. & type of desired batteries, which shall be part of the system to be offered. [The batteries of known & reputed world – class manufacturer will only be accepted.] The maintenance free-batteries, VRLA type shall only be acceptable. The detailed technical specification of batteries with their working life is also to be specified and provided with the offer.</p> <p>b) The firm should also provide battery change over unit for battery banks so that any bank can be connected to any UPS system.</p>
13.	<p>The battery charger should have provision of</p> <p>(i) Monitoring battery temperature and accordingly adjusting the charging level to enhance the battery life.</p> <p>(ii) Programmable battery charging which can be programmed to enhance battery life.</p>
14.	The UPS system should have communication port RS 232/RJ45 and should be configurable by Control computer. Suitable software for monitoring & diagnostics etc. should be supplied.
15.	The UPS system should be designed with scientific forced air-cooling for proper ventilation. Acoustic noise level should be kept at minimum.
16.	The UPS system output should be isolated from the DC circuit of the UPS.
17.	<p>The UPS System quoted must conform to the latest international standards of safety and EMC. The conformance to such standards (indicating standard's name & number) must be stated in compliance statement. A certificate issued to OEM by authorized international/national agencies should be submitted along-with the declaration from OEM in this regard. In general, following standards should be met:-</p> <p>a) Safety: IEC 62040-1 / EN 50091-1</p> <p>b) Emission and Immunity: IEC 62040-2, Class A / EN 50091-2 (Class A)</p> <p>c) Performance: IEC 62040 –3/ EN 50091 – 3</p> <p>d) CE-Marked in accordance with EEC directives 73/23 "low voltage" and 89/336 "electromagnetic compatibility"</p>
18.	The UPS manufacturer must be ISO 9001-2015 certified company. A copy of the certificate should be enclosed with the offer.

5.4.1.2: Operational Features and Technology of UPS

1.	Technology:	The UPS shall be designed to operate as true on-line, double conversion DSP controlled type UPS strictly as per the definition of IEC 62040-3 as follows:
----	-------------	--

a) Normal Operation:

The UPS inverter should continuously supply the critical AC load. The rectifier & charger should take power from the AC input source, convert it to suitable DC and supply to the inverter as well as charge the Batteries on Automatic Float cum Boost Mode.

b) Upon Mains Failure:

Upon failure of AC input power, the critical AC load should continue to be supplied by the inverter, which should obtain power from the battery. There shall be no interruption in power to the critical load upon failure or restoration of the AC input source (Mains/ DG).

c) Upon Mains Restoration:

Upon restoration of AC input power, the Rectifier/Charger should automatically restart walk-in and gradually take-over the supply to inverter and charging to the battery.

d) Static Bypass:

Each UPS Module should have in-built 100% rated static Bypass Line. In two UPS Modules connected in Parallel redundant Current Sharing Mode, in the event of any fault in one UPS, the faulty UPS should isolate itself and the healthy UPS, which normally shares the load 50%, should take-over the full load.

All the loads should be transferred to the Static Bypass Line of the UPS without any break if the input frequency is within 50 Hz and with a break below 20 milliseconds if the input frequency is beyond 50 Hz for the following conditions:

- i. If both the UPS fails simultaneously
- ii. If overload beyond 150% for 1 minute is faced by the UPS
- iii. If both UPS sense over temperature (i.e. inverter exceeding 85 Deg Celsius simultaneously).

If both the UPS inverters are put-off:

2.	MTBF of the System:	Minimum 150000 Hrs
3.	Capacity:	20 KVA at power factor 0.9
4.	Overall Efficiency: (From I/P. to O/P of the U.P.S. system)	>94% (for all loads from 50% to 100%)

5.4.1.3 Feature of Rectifier Section of UPS

S. No.	Parameters	Specifications
1.	Technology	DSP Controlled IGBT Rectifier to reduce the harmonics.
2.	Input	3-phase, 4-wire plus Ground
3.	Input Voltage	320 to 475 V (at full load)
4.	Input Frequency	47 – 53 Hz
5.	Input Power factor	≥0.99
6.	Input Current Harmonic Distortion (THDi)	≤ 3%
7.	Soft Start (0-100%)	> 10 Sec

Signature
06.08.2024

LR

Signature

Note: Bidder should Specify the following Parameters for quoted UPS system

i)	Rectifier Input current (Max.)	
ii)	Max. Rectifier output current	
iii)	Rated Output current (with battery in fully charged state)	
iv)	Max. Output Voltage	

5.4.1.4 Feature of Inverter of UPS:

1.	Technology	Fully DSP based IGBT/PWM Inverter
2.	Output Voltage a) Nominal: b) Static:	3-phase, 4-wire plus Ground 380V- 415V AC (adjustable), 50Hz 400 \pm 1% V AC, 50Hz
3.	Output voltage regulation: a) 100% Balanced load b) 100% Unbalanced load c) Transient response (100% step loading) d) Recovery time to steady state (\pm 1%)	< \pm 1% \pm 2% < 5% < 5 msec.
4.	Output frequency regulation a) Line Connection: b) Self-Connection:	\pm 1% (meeting input frequency range of 47-53 Hz.) \pm 0.05%
5.	Output voltage Distortion: (at rated load)	< 1% linear load, <3% non-linear load with 3:1 crest factor
6.	Audible noise level at 1 meter.	58 dBA or better
7.	Overload capacity: (a) Inverter (b) Bypass Mode	Upto 110% –10 min, Upto 133% --1 min Upto 110% continuously at rated current 110% to 150% 10 min > 150% 2 seconds
8.	RF suppressions:	As per BIS & EMC standard.
9.	Computer Interface:	RS 232/RJ45 Interface
10.	On-Line Battery testing:	Required
11.	(a) Mains failure, (b) Battery Low, (c) UPS Fault	Bidder to provide Audio/Visual alarm at remote location.

12.	Front panel Display (Please submit the details of front panel display)	LED mimic with LCD display. The LCD should display the following: a) Input side: i) Voltage ii) Current iii) Frequency b) Output side: i) Voltage ii) Current (RMS value) iii) Frequency c) Intermediate DC: i) Voltage ii) Current iii) Remaining time (in minutes) d) Bypass: i) Voltage ii) Current iii) Frequency e) Alarm History
<p>Note: Bidder should Specify the following Parameters for quoted UPS system</p> <p>i) Total system losses at nominal load (with charged battery)</p> <p>ii) Size of LCD panel for monitoring should be 50 x 100 mm minimum</p>		

5.4.1.5 Battery Bank & Battery of UPS System

The bidder should submit battery sizing calculation from Battery OEM justifying following points:

- No. of Cells
- Capacity of Cell (Ah), (By considering the K factor, efficiency of system, Temperature correction factor, Ageing correction factor, etc.)
- DC bus voltage
- Minimum surface area required for installation of battery bank

1.	Battery Bank Capacity	Minimum 18000 VAH (for each UPS)
2.	Nominal output current capacity	Minimum 75 AH
3.	No. of Battery String	1 no. for each Battery Bank (one battery bank with each UPS)
4.	DC Voltage of the battery bank	Should be Minimum 360 V
5.	Type:	12 V of Maintenance Free Valve Regulated Lead Acid (VRLA) . (Please submit the catalogue of offered battery) with its detailed specifications along with the charging & discharging characteristics (Graphs from the OEM).

Signature
06.08.2024

Signature

Signature

6.	Backup time:	Minimum 15 minutes (at the End of Life (EOL) of Battery) for 100 % load with each UPS system
7.	Charging Voltage	Float: 2.23-2.27 V per Cell at 27°C
8.	Cutoff Voltage	1.70-1.75 V per Cell (should be Selectable)
9.	Floating Voltage regulation between no load & full load.	< 2% or better.
10.	CODES & STANDARDS	The supplying battery manufacturer shall be ISO 14001:2015 certified. The battery design shall be of proven technology. The manufacturer shall have 5 years of field experience. ISO 14001:2015. Certificate Copy for 'VRLA Battery' must be attached with the offer.
11.	DESIGN	All cells within the battery string shall be of the same manufacturer and model. The cells shall be "valve-regulated" (maintenance free) type.
12.	Life	4 Years minimum designed life at 27 degrees C on full float.
13.	Life Cycling Characteristics	Each battery shall be designed to provide 1700 cycles at 20% depth of discharge (DOD) at 27 degrees C and 400 cycles at 80% DOD at 27 degrees C.
14.	Recharge Rate	The battery shall be capable of a 90% recharge within 12 hours.
15.	Operating Temperatures and altitude	The battery shall be capable of operating in temperatures ranging from 0°C to +40°C. Battery shall withstand hard freezing without damage to the alloy, plates, or cell container assembly. The battery shall be capable of operating at a maximum of 2000m from ground level (AMSL).
16.	Gassing	No special ventilation shall be required under normal operating conditions. No specialized "battery room" shall be required to house the battery unit.
17.	Battery Orientation	Battery shall have front or Top accessible terminals with clear removable covers to facilitate visual inspections and allow ease of service.
18.	Self-Discharge	The battery shall have a maximum self-discharge rate of 0.5-1.0% per week at 27°C.
19.	Housing	The Battery system should be installed & supplied with M S Racks (stand).
20.	Product Identification Label	Each battery shall have a self-adhering label identifying the product manufacturer, model and nominal Amp/Hour capacity. The label must be readily visible from the front of the battery. The label shall not wear out throughout the life of the battery.

21.	Capacity Testing	Each cell shall be capacity tested at the manufacturing facility as per standard battery testing procedure. For each battery, battery performance tables and curves shall be submitted with the supply. The curves may be obtained by test or by calculation.
22.	Leak Detection	Integrity of the container and post seals shall be verified in the cell manufacturing process using an automated helium leak detection process.
23.	Seismic Requirements	Cells shall be packaged in steel modules that meet Seismic requirements when stacked horizontally.
24.	Accessories	<p>Each battery shall be furnished with the following accessories:</p> <ol style="list-style-type: none"> 1. Each battery system shall include the necessary inter-module connectors and terminal plates. The connectors shall be lead-tin plated copper and shall include stainless steel hardware. 2. Assembly and connection drawings. 3. Each module shall include an easily removable transparent "snap on" safety shield to cover all connectors.

Himanshu
06.08.2024

SA

5/10

5.4.2 Isolation Transformer

The Isolation Transformer should be Three Phase, naturally cooled type, housed in steel cubical provided with cast iron wheels at bottom and should have Hooks for lifting the unit. The cubical enclosing the Isolation Transformer should have sufficient openings (doors and removable covers) for ease of operation and maintenance of the system.

S. No.	Parameter	Specification
1.	AC Input	Delta 3-phase, 415V \pm 10% (phase to phase)
2.	AC output	Star 3-phase, 415V \pm 5% (phase to phase) 240V \pm 5% (phase to neutral)
3.	Frequency	47 to 53 Hz
4.	Capacity	30 KVA
5.	Duty cycle and use	24x7 Continuous, Indoor
6.	Common mode noise rejection	Better than 110 dB
7.	Inter winding capacitance	Less than 0.005 pF
8.	Load regulation	<4%
9.	Insulation resistance	More than 500 Mega Ohms at 500V
10.	Terminals	Studs on fiber glass plate at rear
11.	Cable entry	Bottom

5.4.3 Automatic Voltage Regulator

The unit should be self-contained, compact, efficient and highly reliable for 100% duty cycle, 365 days a year and based on field proven design using modern technology.

S. No.	Parameter	Specification
1	Input Voltage Range	340 V - 460 V 3 phase , 4 wire AC
2	Capacity	30KVA
3	Output voltage and rated operating frequency	400V \pm 1% three phase AC (230 V Phase to neutral) Voltage should be adjustable to \pm 5% with control located on front panel
4	Voltage regulation	\pm 1 % from no load to full load
5	Frequency	AVR should work satisfactorily with input frequency range of 50 \pm 3 Hz
6	AVR Type	Indoor, servo controlled
7	Speed of correction	6 volt per second or better
8	Metering	(i) Digital meters shall be provided with selector switches for measurement of phase to phase and Phase to neutral voltage on all three phases for input and output (ii) Digital ammeter in output on all three phases (iii) Indications , on control panel should be provided for input/ output voltage status

9	Electrical protection	Protection against overload, short circuit surge voltage due to system faults, switching operations and hotspot temperatures
10	Main selector switch	Four position heavy duty control switch shall be provided for the following operations (i) OFF- The input is cut off (ii) Test - Input is through but output is cut off (iii) ON- Input and out put both are through By Pass- AVR gets isolated and input gets directly connected to output
11	Input output connection	Terminal for connection
12	Cooling	Natural Air-cooled
13	Manual control	Provision for manual control of each phase in case of failure of automatic controls system
14	Efficiency	90% or better

5.4.4 Specification for Sub Distribution Board

Suitable Sub Distribution Board (SDB) must be supplied and installed which will distribute the AC power to the rack of the Compression and Monitoring system. The suggestive block schematic is given for general idea about the configuration of SDBs (Please refer DRG No.2). Bidder shall submit schematic diagram in advance before installation for approval.

5.4.5 Earthing System

- Earth pits should consist of Copper Earth electrode (diameter 20 mm (min)), insulated copper strip/wire (75 Sq. MM (Min)), Chemical earth fill compound with fast discharge characteristics, water absorbing gel, perforated Hard HDPE pipe (diameter 40 mm (min)), funnel, water supply provision upto each earth pit (preferably from A/c condenser), 10 feet depth (min) and 1 feet diameter (min.). Earth pit should be prepared so that earth resistance is less than 1 ohms –typical depth of earth pit is 10 feet minimum. (Sample picture is enclosed at DRG No. 3).
- All earth pits shall be extended upto earth terminals mounted on wall with insulated copper strip (75 Sq.mm (Min)) in the equipment room. All equipment racks shall be directly connected to Earth Terminals with insulated multi strand copper wire (25 sq mm (Min)) with copper lugs at both ends. (Sample picture is enclosed at DRG No. 4).
- The earth resistance should be less than 1 ohm. In case of hilly terrain/Rock area, more than one earth pits may be provided in parallel connection to achieve less than 1 ohm resistance.

Himanshu
06.08.2024

Lok

20/8/24

6. Physical, Environmental & Mechanical Specifications

6.1 Power Supply

Equipment shall operate from a wide range of power supply voltages without interruption or damage.

Parameter	Specification
(a) Voltage Range	220/240 V AC nominal
(b) Frequency	48-52 Hz

6.2 Environmental Specifications

Parameter	Specification
(a) Operating Temperature (Indoor)	0°C to 40°C
(b) Operating Temperature (Outdoor door)	- 10°C to 60°C
(c) Storage Temperature	- 20°C to 60°C
(d) Humidity (Indoor)	0 to 85% non-condensing
(e) Humidity (Outdoor)	0 to 95%
(f) Altitude	2000 m

6.3 Mechanical Specifications

Indoor equipment shall be rack mounted.

Parameter	Specification
(a) Construction	Modular approach, EIA RS-310C, 19" rack-mount

Signature
20.08.2024

Signature

Signature

7. Complement of Equipment for the Earth Station:

- 7.1 The make and model/part no. of each and every equipment/item/installation material etc. should be clearly mentioned in the offered Bill of Material (BoM).
- 7.2 The suggestive Bill of Material (BOM) has been provided in **Annexure-I of Appendix-D**. The bidder is required to provide the complete list of equipment, software and accessories etc. offered to meet the specifications requirement. The quantity of each item including sub-module etc. are to be specified clearly and compulsorily, failing which the bid is liable to be rejected summarily. The following is the Proforma for the BOM:

S. No.	Description of Item as per Specification (Suggestive BOM)	Description of Item as offered by the Bidder	Qty.	Total Quantity as per Suggestive BOM	Make	Model
1	2	3	4	5	6	7

- 7.3 Any substandard equipment included in the offer may result into the rejection of complete offer with the sole responsibility of bidder.
- 7.4 The offer should also include the detailed technical brochure and technical manual containing all the technical specifications of all the offered equipment, accessories, and software etc.
- 7.5 General specifications applicable to all equipment wherever applicable have been given in Clause No. 5.

Himanshu
06.08.2024

st

13/08

8. General

8.1 Compliance and OEM Authorization:-

8.1.1 The bidder must submit a point-by-point compliance statement in respect of all the points, sub-points and paras laid down in this specification from page 1 a) in the format as indicated below along with the bid.

S. No. of DD specs.	DD Specs.	Compliance (Yes/No)	Performance fig. of equipment offered.	Deviations, in case of non-compliance	Additional items if any required to make the system Compliant to DD specs.	Features in the system offered Which exceed DD specs.	Page No.	Remarks
1								
2								
3								
4								

8.1.2 In addition to the above, compliance from respective OEMs (not from their Indian representatives) in respect of the equipment as listed below should necessarily be given, in respect of all the points, sub-points and paras laid down in the Technical Specification of the respective equipment in the format as given above. The OEM should necessarily record the performance figure of the equipment offered in the quote for which the compliance statement is required.

A	Input and Baseband System
1.	Analog Audio & HD/SD-SDI Video Multiplexer Unit (Embedder)
2.	Analog Audio & HD/SD-SDI Video De-multiplexer unit (De-Embedder)
3.	HD-SDI & SD-SDI Distribution Amplifier (DA) and Rack frame (Chassis)
4.	DFC Link from MSR to ES (Optical transmitter, receiver and optical fiber cable)
B	Digital Compression System
1.	32x32 HD/SD SDI Router
2.	Encoder
3.	IP Data Switch
C	Satellite Modulator
1.	Digital Satellite Modulator
2.	RF Redundancy Switch
D	Downlink Monitoring System
1.	Professional IRD

[Handwritten signature]
26.03.2024

[Handwritten signature]

[Handwritten signature]

2.	17" video monitor
3.	Dual 9" video monitor
4.	8 channel audio monitor
5.	Audio ampli-speaker
6.	4K/ UHD, size - 55 inch or more Display/TV
7.	19" Rack Mountable, Foldable 17" or bigger display with PC
E	Power Supply System
1.	30 KVA Isolation Transformer
2.	30 KVA AVR
3.	20 KVA UPS with Batteries

8.1.3 The bidder is also required to submit authorization in respect of the equipment as listed above at Sl. No. 8.1.2 in their favour from respective OEMs (not from their Indian representatives) on their letter heads along with the bid as prescribed in Annexure II of Appendix-D.

8.1.4 Mere signature on a copy of Doordarshan specifications shall not be accepted as a compliance statement.

8.1.5 The compliance statement in respect of Technical Specification of the equipment should be supported by highlighted record of these in the relevant technical literature/data sheets enclosed with the tender and a clear reference to the attached supporting document should be given in the remarks column against each & every specs. Any offer without proper supporting document of each & every specs and containing only a commercial hand out/pamphlet is liable to be rejected.

8.1.6 Data sheets should be submitted in respect of all offered equipment. Any deviation from the specification detailed in the compliance statement is to be highlighted separately. Page no. of location of data sheet should be given in page no. column above.

8.1.7 Offers without proper & duly completed compliance statement are likely to be rejected with the sole responsibility of bidder and no further claim/ correspondence will be entertained.

8.2 Documentation

8.2.1 One set of technical manual for all the equipment are to be provided along with the tender to facilitate the technical evaluation, otherwise the tender is liable to be ignored.

8.2.2 The successful bidder will have to supply set of printed technical & user manuals along with factory test report of all the offered equipment.

8.2.3 Operation Manual for all equipments should also be supplied on DVD/USB with search facility.

8.2.4 All offered software should have perpetual validity and should be in the name of Doordarshan. All software backups should also be supplied on DVD/USB storage.

8.2.5 The successful bidder must submit the firm's self-certified copies of import licenses at the time of commissioning in respect of RF equipment for issuance of operating license for WPC.

Signature
06.08.2024

ft

Signature

- 8.2.6 For facilitating maintenance issues, the bidder must submit the firm's self-certified copies of Bill of Entry/Bill of Laden/Custom Invoice of all imported items to DG; DD.
- 8.2.7 The successful bidder must ensure that all Invoices bear serial numbers of equipment to meet the requirement of WPC.

8.3 Guarantee/Warranty, Material & workmanship and After Sales Service Support:

8.3.1 The Guarantee, warranty of material and workmanship will be covered by General Terms and Conditions (GTC) at APPENDIX-B of the Bid document except the following:

- a) All the offered equipment shall be guaranteed against any manufacturing defect for a period of 5 (FIVE) years from the date of Commissioning.
- b) Any part failing during the guarantee period shall be repaired/replaced free of charge by the successful bidder at site. For repairing of any defective equipment during guarantee period, the defective module or equipment requiring repairs will be handed over to local office/local authorized representative/ dealer who will arrange repairs locally at site or send/export the defective modules to OEM factory and re-import/send back after repairs.
- c) It is the responsibility of local office/ Authorized representative/ dealer of the bidder to arrange the repair/ replacement of faulty items for Doordarshan i.e. no transportation charges would be paid by DD for transporting the defective/ repaired items, if required to be removed from site, during the guarantee period.
- d) Guarantee period of Equipment or spare parts thereof replaced is to be extended corresponding to the outage period from the date of acceptance, if the failure rectification takes more than 30 days time.
- e) If bidder is not the OEM, then the guarantee/ warrantee in respect of the equipment as mentioned in Clause 8.1.2 shall be provided by the bidder through respective OEMs. A certificate, duly signed by the OEM on the OEM letterhead, in this regard of the respective equipment, must be submitted with the offer by the bidder as prescribed in Annexure III of Appendix D.
- f) If bidder is not the OEM, then after sales service support for additional 2 (Two) years for the repairs/ maintenance after the completion of guarantee/ warrantee period in respect of the equipment as mentioned in Clause 8.1.2 shall also be provided by the OEM either directly or through his representative in India. A certificate, duly signed by the OEM on the OEM letterhead, in this regard of the respective equipment must be submitted with the offer by the bidder as prescribed in Annexure IV of Appendix D.

8.4 Inspection and Commissioning:

The inspection of material will be carried out by the authority specified in the Purchase order. The material will be accepted only after the same has been found satisfactory after inspection and duly marked and sealed by the Inspection Authority. In addition to "General Terms and Conditions" (GTC) at Appendix-B of the Bid document, the inspection of material/equipment will be carried out as follows:

- 8.4.1 All the equipment to be supplied against the supply order for this tender shall be subjected to pre-dispatch inspection before the commencement of the installation at bidder's premises/Delhi or at site by Doordarshan. The successful bidder should produce the factory test reports of all the offered equipment to facilitate inspection.

Handwritten signature and date: 26/03/24

Handwritten initials: fall

Handwritten number: 500

- 8.4.2 Post installation inspection of the system will be carried out by a team of Doordarshan Officers authorized by Doordarshan Directorate and based on approved Acceptance Test Procedure (ATP).
- 8.4.3 A draft copy of ATP (Acceptance Test Procedure) must be submitted by the bidder one month in advance of the proposed date of inspection of system to Doordarshan Directorate for approval. ATP should describe the standard test procedure of individual equipment and of the integrated system chain. The factory test report will not be treated as ATP.
- 8.4.4 The accepted ATP / approved ATP with or without changes shall be sent back to the successful bidder which will be used for inspection and commissioning of ES equipment by DD Engineer(s) at site. All the test & measurement equipment required for the inspection as per the approved ATP are to be provided by the successful bidder.
- 8.4.5 The SITC certificate will be issued by the team of Officers appointed at S.N. 8.4.2 above.

8.5 Delivery Period

Four months from the date of issue of purchase order or Three months from the date of the Decision Letter provided by DD in respect of RF equipment, whichever is later.

8.6 Pre-bid Conference

- 8.6.1 A pre bid conference on technical Specifications and other issues shall be held on date and time specified in the NIT. All prospective bidders may attend the pre bid conference to discuss their queries and suggestions.
- 8.6.2 All the queries and suggestions should be sent to Doordarshan at least 2 days before the date of pre bid conference. No queries/ suggestions shall be entertained after pre bid conference.
- 8.6.3 Amendments subsequent to the pre bid conference shall be sent to prospective bidders, who have purchased tender document, by e-mail/fax/ post.
- 8.6.4 It shall be bidder's responsibility to check for any amendments/addendum on the website before submitting their duly completed bids.

8.7 Check List and Enclosures

The bidders may ensure the following check list while submitting the bid including some important list of enclosures for ease of technical evaluation along with list of enclosures mentioned in Appendix-A, Appendix-B, and Appendix-C of Tender Bid.

(Additional Check List)			
S.No.	Description	YES/NO/NOT APPLICABLE	Remarks
1	Whether documents related to fulfillment of the eligibility criteria for Bidder and OEMs as per Clause 3 have been submitted?		
2	Whether the BOM has been submitted in the prescribed format as given in Clause 6?		
3	Whether all equipment and accessories as given in Annexure-1 of Appendix-D have been included in the offered BOM?		

Handwritten signature
06-08-2024

Handwritten initials

Handwritten initials

4	Whether the compliance statement from the bidder as required in Clause 8.1.1 has been submitted?		
5	Whether the compliance statements from the respective OEMs for equipment/system mentioned in Clause 8.1.2 have been included?		
6	Whether the Authorization (Annexure-II of Appendix-D) as required vide clause no. 8.1.3 in respect of equipment as mentioned in Clause 8.1.2 from respective OEMs have been included?		
7	Ensure that the relevant technical brochures/manuals containing all the parameters of technical specifications of all the offered equipment and accessories have been included with proper indexing for ease of identification?		
8	Whether the page numbers of the relevant enclosed technical data sheet/manual against each parameter of the technical specifications have been given in the compliance statements?		
9	Whether the requisite undertakings for guarantee/warranty (Annexure-III of Appendix-D) and after sales service support (Annexure-IV of Appendix-D) by OEMs as required vide Clause no. 8.3.5 & 8.3.6 have been submitted?		
10	Whether the requisite undertakings as required by Annexure-V of Appendix-D by Bidder have been submitted?		
11	Ensure that no alternate item has been offered.		
12	Ensure that the Un-priced BOM has been included.		
13	Any other item mentioned elsewhere in the tender.		

OEM'S LETTER HEAD

CERTIFICATE FOR AUTHORIZATION

Date:

Tender No. :

We, M/s (Name and Address of the OEM), do hereby authorize M/s..... (Bidder's name), having its office at (Bidder's address) to submit the bid and sign the contract with Doordarshan for the products offered by us against the above tender.

Signature

Name & Designation of authorized signatory.....

Name of the OEM -

Stamp

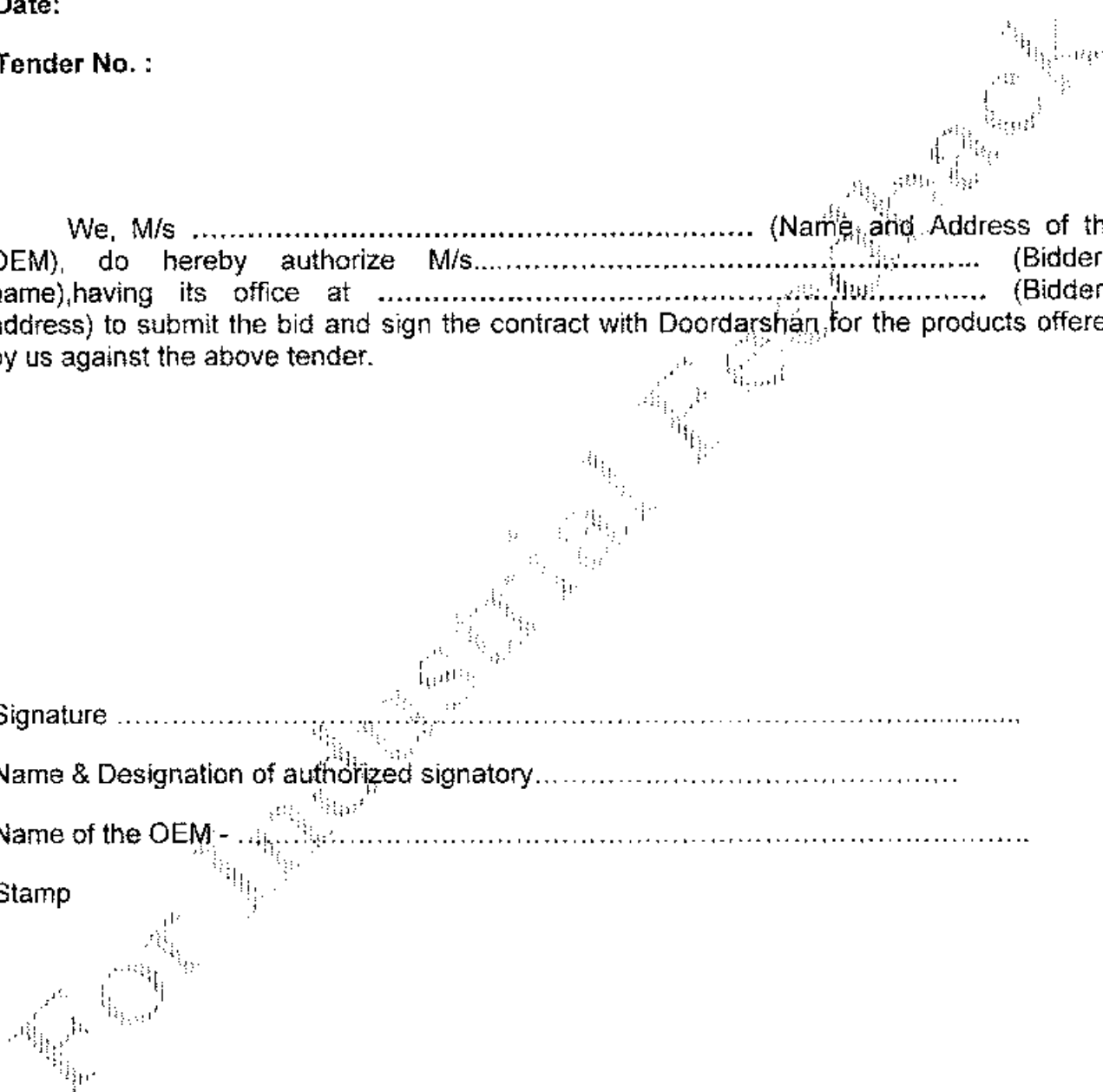

Himanshu
08.08.2024

Handwritten marks/signatures at the bottom right of the page.

OEM'S LETTER HEAD

CERTIFICATE FOR GUARANTEE

Date:

Tender No. :

We, M/s (Name and address of the OEM), do hereby confirm that:

All the offered equipment shall be guaranteed against any defect for a period of 5 (Five) years as per terms and conditions of tender document.

1. Any part failing during the guarantee period shall be repaired/replaced free of charge by the successful bidder at site. For repairing of any defective equipment during guarantee period, the defective module or equipment requiring repairs will be handed over to local office/local authorized representative/ dealer who will arrange repairs locally at site or send/export the defective modules to OEM factory and re-import/send back after repairs.
2. It is the responsibility of M/s (their local office/ Authorized representative/ dealer of the bidder) to arrange the repair/ replacement of faulty items for Doordarshan i.e. no transportation charges would be paid by DD for transporting the defective/ repaired items, if required to be removed from site, during the guarantee period.
3. Guarantee period of Equipment or spare parts thereof replaced is to be extended corresponding to the outage period from the date of acceptance, if the failure rectification takes more than 30 days time.
4. All software being offered, are to be licensed to Doordarshan on perpetual basis without specifying any time limit or without specifying end of life of the software. Software upgrades within warranty period will have to be supplied free of cost.

Signature

.....
Name & Designation of authorized signatory.....

Name of the OEM-

Stamp

Handwritten signature and date: 06.08.2024

Handwritten initials

Handwritten signature

OEM'S LETTER HEAD**CERTIFICATE FOR AFTER SALES SERVICE SUPPORT**

Date:

Tender No. :

We, M/s (Name and address of the OEM), do hereby confirm that after sales service support for additional **Two (2) years** for the repairs/maintenance of offered products after the completion of **Three (3) years** guarantee/ warrantee period shall be provided through our representatives/authorized dealer/service provider for the offered equipment and accessories in India as mentioned below:

S. No.	Name of the authorized person	Name & Address of authorized After Sales & Support Office/Firm	Telephone/ Fax	Email of the concerned personnel
1				

Signature

Name & Designation of authorized signatory.....

Name of the OEM -

Himanshu
06.08.2024

Annexure V of Appendix-D

BIDDER LETTER HEAD**DECLARATION BY THE BIDDER**

1. Bill of Material (BOM)- : [Yes/No]
2. Bidder's compliance (As per specs clause no. 8.1.1) : [Yes/No]
3. The copy of Dealer Possession License in case of possession of RF equipment (if applicable) : [Yes/No]
4. Copy of the Memorandum of Understanding (MOU) of Consortium/Joint Venture (If Applicable) : [Yes/No]
5. OEM Compliance for following equipment from their respective OEMs (as per clause no. 8.1.(b)):

S. No.	Name of equipment	Name of OEM	OEM compliance submitted (Yes/ No)
i			
ii			
...			

6. Certificate for Authorization for following equipment from their respective OEMs:

S. No.	Name of equipment	Name of OEM	Authorization certificate submitted (Yes/ No)
i.			
ii.			
...			

7. Certificate for Guarantee for following equipment from their respective OEMs:

S. No.	Name of equipment	Name of OEM	Guarantee certificate submitted (Yes/ No)
i.			
ii.			
iii.			
-			

8. Certificate for After sales service support for following equipment from their respective OEMs:

S. No.	Name of equipment	Name of OEM	After sales service support certificate submitted (Yes/ No)
i.			
ii.			
iii.			
-			

9. Datasheet for the offered equipment as per offered BOM: [Yes/No]

- i.
- ii.
- iii.

Signature

Name & Designation of authorized signatory

Name of the Bidder

Stamp

Date:

Handwritten signature and date:
 Himanshu Choudhary
 06.08.2024

Handwritten initials and numbers:
 SK
 13710

BIDDER'S LETTER HEAD

CERTIFICATE FOR WORK EXPERIENCE

Date:

Tender No. :

We, M/s <Name and address of the bidder>, do hereby confirm that details of Work Experience are as follows:

S. No.	Description of Work Experience of the Bidder	Details of Work Order No. with date	Copy of Work Order uploaded with bid (YES/NO)	Sr. No. of work/item of the uploaded work order to be considered for work experience of the bidder	Amount /Value in Rupees of the work to be considered for work experience of the bidder	Bidder's Work Experience Category (Please select anyone option i.e. (a) One work of 80% or (b) Two work of 60% or (c) Three work of 40% of Estimated Cost)
1						
2						
3						

Signature

Name & Designation of authorized signatory of the Bidder.....

Name of the Bidder.....

Stamp of the Bidder

Signature
06.08.2024

Signature

Signature

LIST OF TOOLS

S. No.	Tools	Qty.
(1)	Soldering and de-soldering station(similar to weller make)	1 Set
(2)	T-Handle Hex Allen Keys Set	1 Set
(3)	Flat & Star Head Screw driver Set (Similar to Taparia)	1 Set
(4)	Flat & Star watch maker Screw Driver Set	1 Set
(5)	Flat Plier	1 No.
(6)	Nose Plier	1 No.
(7)	Edge Cutter	2 No.
(8)	Wire Stripper	1 No.
(9)	Crimping Tool for RG11 and RG59U Cable	1 No.
(10)	Crimping Tool for RJ11 and RJ45 Cable	1 No.
(11)	Crimping Tool for Power Cable	1 Set
(12)	Box Spanner Set	1 Set
(13)	D-Spanner Set	1 Set
(14)	Ring Spanner Set	1 Set
(15)	Adjustable Wrench	1 No.
(16)	File Set	1 Set
(17)	Handheld Magnifying Glass	1 No.
(18)	Toolkit Box (Hard case type)	1 No
(19)	Battery operated multifunctional (screw, unscrew, drilling etc.) hand machine (Similar to Bosch, Am-Tech or equivalent) with battery charger and other accessories.	1 Set
(20)	Any other special tool required as per offered equipment	1 Set

Itimarshekh
06.08.2024

Ldt

13/08/24

Suggestive Block Schematic for Upgradation of Earth Stations at DDK Itanagar, Agartala, Kohima, Imphal, Gangtok and Portblair

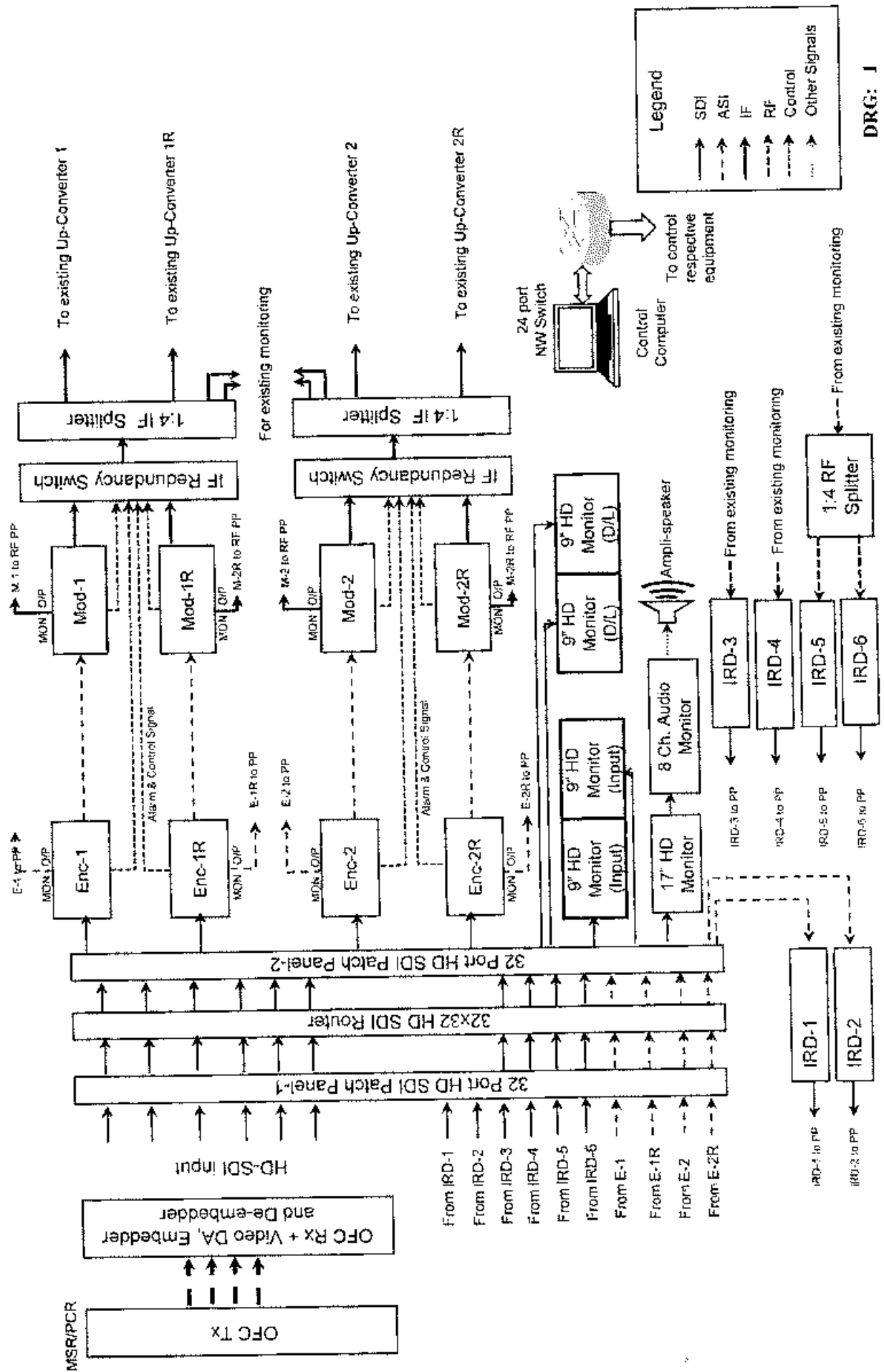

Legend

- SDI
- - - ASI
- IF
- RF
- Control
- ... Other Signals

DRG: 1

Handwritten signature and date: 10/06/2024

Handwritten mark

Handwritten mark

Upgradation of Earth Stations at DDK Itanagar, Agartala, Kohima, Imphal, Gangtok and Portblair : Power Supply System

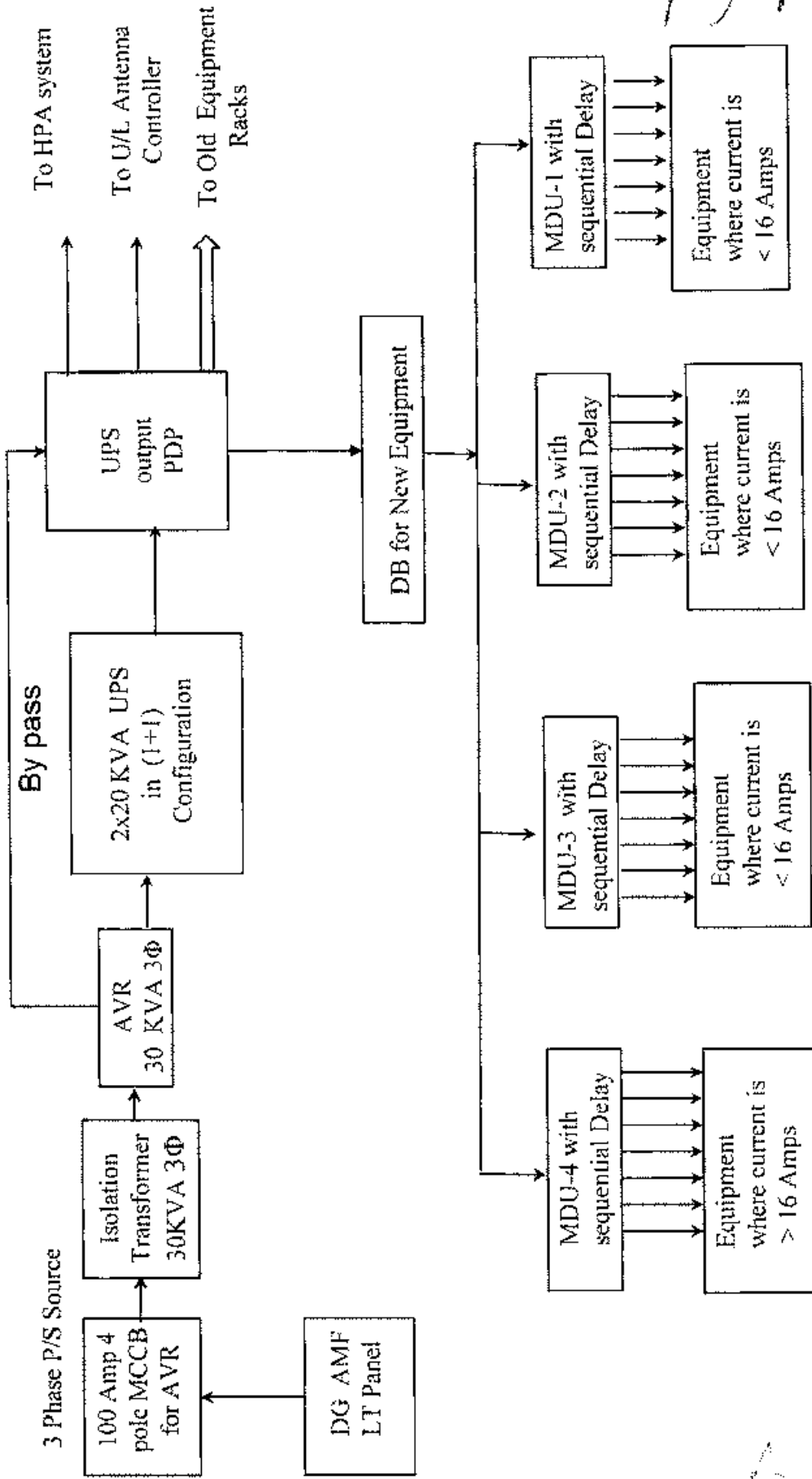

Handwritten initials

06.08.2024
Handwritten signature

DRG:2

Page 59 of 63

Handwritten marks

Upgradation of Earth Stations at DDK Itanagar, Agartala, Kohima, Imphal, Gangtok and Portblair :
Earth Pit

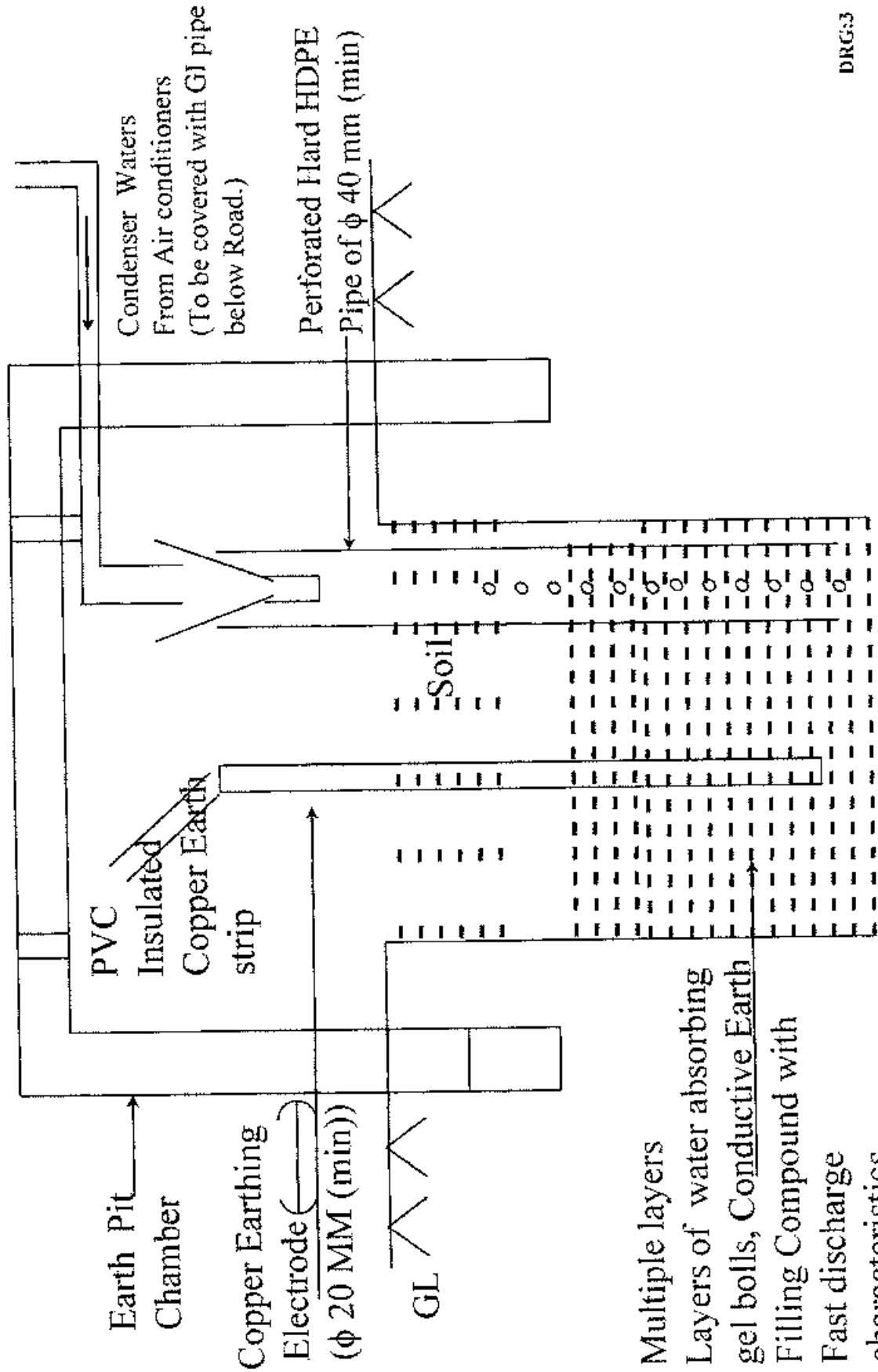

DRG:3

Handwritten signature and date: 6-2-2024

Handwritten mark

Upgradation of Earth Stations at DDK Itanagar, Agartala, Kohima, Imphal, Gangtok and Portblair :
Earth Terminal



DRG: 4

Page 61 of 63

Shimran Kaur
06.03.2024

Sub

1/3/24

1336887/2024/Sat. Design Section - DG DD

Suggestive Bill of Material (BOM) for upgradation and replacement of Earth Station at DDK Itanagar, Agartala, Kohima, Imphal, Gangtok and Portblair				
S. No.	Description of Item as per Specification (Suggestive BOM)	Qty. per site	Total Qty.	Budgetary Quote Price
A. Link from MSR to Earth Station				
1	Analog Audio & HD/SD-SDI Video Multiplexer Unit (Embedder) along with suitable breakout cables.	2 Nos.	12 Nos.	
2	Analog Audio & HD/SD-SDI Video De-multiplexer unit (De-Embedder) alongwith suitable breakout cables.	2 Nos.	12 Nos.	
3	HD-SDI & SD-SDI Distribution Amplifier (DA) with reclocking (i.e. 1:4 or more output).	2 Nos.	12 Nos.	
4	19 inch Rack Frame Mounting (Chassis) with auto switchable redundant Power Supply Unit.	1 No.	06 Nos.	
5	Digital Video Cable to be laid for redundancy between MSR and Earth Station to transport video with embedded audio directly	300 M	1800 M	
OFC Link from MSR to ES consisting of (for 6 Earth Stations):				
6	Single channel Optical Transmitter unit.	4 nos.	24 Nos	
7	Single channel Optical receiver unit.	4 nos.	24 Nos	
8	Chassis to house the above OFC Link units with dual power supply units and control card (One chassis to be installed in MSR and one in Earth Station).	2 sets	12 Sets	
9	Water resistant, Armoured optical fiber cable (8 core)	200 M	1200 M	
10	Any other item found essential to meet DD specifications. Note: If offered, bidder must provide the detail.	1 lot	6 lot	
B. Compression System				
11	MPEG 4 Encoders in (1+1) redundancy configuration consisting of : Digital Encoder operating in 4:2:0 and 4:2:2 mode with MPEG-4 & MPEG-2 compression (Noise reduction hardware/software for encoders BISS-1 & BISS-E Software for Encoders Internal Remux Option, Audio options Auxiliary data input option etc as per specs)	4 Nos.	24 Nos	
12	Digital Satellite Modulators in (1+1) mode consisting of: Digital Satellite Modulators capable of Modulating in DVB-S and DVB-S2 (one at a time) .	4 Nos.	24 Nos	
13	IF Redundancy switch for managing redundancy of above Modulators.	2 No.	12 Nos.	
14	1:4 passive IF splitter	2 No.	12 Nos.	
15	32 x 32 SDI/ASI router with one XY Control panel and single bus remote control panel.	1 No.	6 Nos	
16	Essential item to complete the installation of Compression system (if any)	1 lot	6 lots	
C. Monitoring & Measuring System				
Input / Downlink / Confidence Monitoring consisting of:				
17	Prof. IRDs (with ASI and L-band inputs and with DVB-ASI, MPEG-2 TS over IP with service filter, SD-SDI, HD-SDI, AES/EBU, SD & HD SDI embedded stereo, Dolby digital (AC-3) 5.1 audio and Dolby Digital Plus 5.1 Audio) along with MPEG-2, 4:2:0, 4:2:2 and MPEG-4, 4:2:0, 4:2:2 decoding and Common Interface slot hardware and BISS mode -1 & BISS-E decryption facility.	6 Nos.	24 Nos	
18	LCD/TFT/OLED 17" Colour monitor with built-in Speaker with SD-SDI and CVBS & Analog Audio Inputs with a suitable rack/tilt mount for proper installation in the monitoring desk.	1 Nos.	06 Nos	
19	Dual 9" LCD/TFT/OLED Monitor with HD/SD-SDI (with embedded audio) and Composite (PAL) Video inputs and suitable power supply (19" Rack mountable)	2 Nos.	12 Nos	
20	Eight Channel Audio Monitor	1 Nos.	6 Nos	
21	4K/ UHD, size - 55 inch or more Display/TV/Panel Units along with Remote, Table Stand Wall Mount Operation manual/User Guide, maintenance manual etc (in electronic or Printed form)	2 Nos.	12 Nos.	
22	High quality Digital Audio Ampli-Speaker having digital AES/EBU and Analog Audio input facility and suitable power supply	1 Nos.	06 Nos	
23	L-band splitter (4-Way). One to be installed and one as cold standby	1 No.	06 Nos.	
24	Digital multi meter (4.5 digits)	1 No.	06 Nos	
25	Essential item to complete the installation of above monitoring system (if any)	1 Lot	06 Lots	
D. Remote control Computer system				
Hardware and Software consisting of:				
26	19" Rack Mountable Foldable 17" or bigger display, keyboard (with Digipad & Mouse Switches) with PC (Intel i7 or better processor, 4 GB or More DDR RAM, 800 GB or more HDD, Windows 11 or latest operating system, minimum 4 nos. USB ports, 1 AGP and 3 PCI Slots, Integrated Audio with external	1 Lot	06 Lots	
27	10/100 Fast Ethernet Switch (24-Ports, one -RU)	2 Nos.	12 Nos	
28	Network Laser Printer (Heavy duty) with Ethernet Port	1 No.	06 Nos.	
29	UPS (ONLINE) 1KVA Capacity	1 No.	06 Nos.	
30	Essential item to complete the installation of Remote Control Computer System	1 Lot	06 Lots	

Handwritten signature
6.08.2024

Handwritten mark

Handwritten mark

1336887/2024/Sat. Design Section - DG DD

S. No.	Description of Item as per Specification (Suggestive BOM)	Qty. per site	Total Qty.	Budgetary Quote Price
E.	Miscellaneous Items			
	Miscellaneous Items for integration of system consisting of:			
31	32 port HD-SDI patch panel 1 RU, normal through, self terminating type suitable up to 3 Gbps bandwidth, 20 dB return loss and 75 ohm normal through type. (One for SDI/ASI Router I/P & one for SDI/ASI Router O/P)	2 Nos.	12 Nos.	
32	10 nos of patch chords (each of one meter length) for by-passing the router in case of failure.	1 Lot	06 Lots	
33	19" standard wired equipment racks for mounting all compression chain and Monitoring chain equipments	2 Nos.	12 Nos.	
34	Required no of Mains Distribution Units (Min 2 nos of 12 Ports each MDU per Rack) with sequential delayed output on start up, output status LED and IEC-3 pin for each equipment in every rack	4 nos	24 Nos.	
35	Supply and installation of 16 Sq mm, 3/4 core, multi strand copper cable from PDP to equipment racks and to be connected with each MDU. (Length of power cable - 60 mtrs)	1 Lot	06 Lots.	
36	Audio, Video, IF, RF etc. Cables with assorted connectors	1 Lot	06 Lots	
37	Essential item to complete the installation of equipment racks (if any)	1 Lot	06 Lots	
38	Earth pits should consist of Copper Earth electrode (diameter 20 mm (min)), insulated copper strip/wire (50 Sq. mm (Min)), Chemical earth fill compound with fast discharge characteristics, water absorbing gel, perforated Hard HDPE pipe (diameter 40 mm (min)), funnel, water supply provision up to each earth pit (preferably from A/c condenser), 10 feet depth (min) and 1 feet diameter (min.). Earth pit should be prepared so that earth resistance is less than 1 ohm. (2 nos. for Baseband and compression and 2 nos. for UPS), each with less than 1 ohm resistance)	04 Nos	24 Nos.	
39	Set of tools including BNC Crimping Tool, RJ45 Crimping Tool, F Connector Crimping Tool, Set of spanners, Set of screw drivers (Magnetic and non magnetic), Set of Allen Keys, Plier, Wire stripper, Wire Cutter, Extractor, Soldering Station, Power Supply Cable crimping Tool (200 Sq. mm) suitable for maintenance of equipments and cables used in the earth station (As per attached list - Annexure -VII)	1 lot	06 Lots	
40	Essential items (if any) required for completing the installation and commissioning work of the system as per Specifications, should be included and quoted. No extra cost will be paid for any extra item declared at a later date for completion of the project installation.	1 lot	06 Lots	
F.	Power Supply System			
41	30 KVA, Three Phase, Naturally Air cooled type Isolation Transformer	1 No.	06 Nos.	
42	30 KVA, Three Phase, Indoor type, Air-Cooled, Servo Controlled, Automatic Voltage Regulator	1 Nos.	06 Nos.	
43	20KVA IGBT/PWM based (Rectifier & Inverter), Fully DSP based Double Conversion UPS system in (1+1) configuration (3 Phase input, 3 Phase Output) with synchronisation kit [Including Transient Voltage Surge Suppressor (TVSS) in input & output (ANSI/IEEE C62.41 1991 C1 (6KV @ 3KA))].	1 Set	06 Lots.	
44	Maintenance Free 12V, VRLA type Battery Bank suitable to provide 15 minutes (minimum) backup (EOL) with each UPS system-18000VAH minimum). Calculation sheet with following details to be provided with the bid. DC Voltage Battery Capacity: No. of Batteries with each UPS:	2 Set	12 Set	
45	Remote panel with interface cables for monitoring of UPS system in Control Room	1 Set	06 Sets.	
46	Suitable Power distribution Panel (PDP) and bus bar with necessary MCCBs for sources to cater supply to new as well as existing equipments, Mains Changeover Switches, Changeover Switches for bypassing UPS, AVR and Isolation Transformer.	1 Set	06 Sets.	
47	Necessary Mains three phase Distribution Boards for distributing UPS output to respective equipment racks	1 lot	06 Lots.	
48	Any other item required for the completeness of the UPS system.	1 lot	06 Lots.	
49	Documentation			
50	Equipment manuals consisting of:			
51	Operation/User Manual Hard copy and Soft copy on CDs with Search facility for all the supplied equipment. (2 Sets for each Kendra, 1 Set for DG/DD and 1 Set each for ADG(NEZ) and ADG(SZ))	1 Lot	06 Lots	
52	All software backups are to be supplied on CDs	1 Lot	06 Lots.	
53	Firm's self certified copies of Import license in respect of RF Equipment (Modulators, Upconverter, HPA, Antenna etc.) for issuance of operating license from WPC. - 4 Sets for each site	1 Lot	06 Lots.	
H.	Training			
54	In India: Two separate Seminars (including Theoretical (alongwith basic study material) & Practical training, hands on experience) for Compression, RF, Monitoring, UPS etc. (minimum for 5 working days) for Doordarshan personnel at each site. (Note: Training will not be treated as part of the delivery period)	1 Lot	06 Lots.	
55	Installation, testing and Commissioning of the complete system at each site	1 Lot	06 Lots	
I.	Installation, Testing and Commissioning			
56	Dismantling the existing compression, monitoring & Power Supply equipment and re-installation, testing and commissioning of the equipments.	1 Lot	06 Lots.	

Himanshu
06.08.2024

ft

6/8/24

9/8/24